

Technical Data Book

Industrial/MPT/EM Tyres



Industrial Tires

Lift Up Your Business!

Continental

Published by

© 2007 by Continental Aktiengesellschaft Hannover.

All rights reserved.

The contents of this publication are the result of many years of research and experience gained in application technology. All information is given in good faith; it does not represent a guarantee with respect to characteristics and does not exempt the user from testing the suitability of products including checking with respect to industrial property rights of any third parties. No liability whatsoever will be accepted for damage, regardless of its nature and its legal basis, arising from advice given in this publication. Products are subject to technical changes as a result of new developments.

Continental's range of publications in this series:

Technical Data Book: Passenger Car Tyres

Technical Data Book: Commercial Vehicle Tyres

Edition 05/2007

Previous Edition 01/2005

Contents

Introduction

Units of measurement and definitions	6
Tyre designations	7

Pneumatic Tyres

Operating instructions	10
New – Tubeless Sealing Ring - TSR	11
Radial Tyres	14
Size range, specifications and tyre load capacities	18
Crossply Tyres	22
Size range, specifications and tyre load capacities	24

SE-Tyres

Continental Super Elastic Tyres	28
Tyre construction	29
New – Innovation CSEasy	30
New – SC20	32
Super Elastic solid tyres	34
Continental Super Clean	35
Size range, specifications and tyre load capacities	36

Press-on Bands

Continental Press-on Bands	42
Rim versions	43
Tread layer designs	43
Steel banded press-on bands	44
Press-on bands with steel wire reinforcement	46

Multi Purpose Tyres

MPT-Radial	48
MPT-Crossply	50
MPT-Operating regulations	52
Load capacities for various maximum design speeds and for special applications	53
Technical data and load capacities – MPT Radial Tyres	54
Recommended tyre pressures for tyres on off-road vehicles	56
Recommended load capacities for use on wheel loaders	57
Technical data and load capacities – MPT Crossply Tyres	58
Size range, specifications and tyre load capacities	60

EM (OTR) Tyres

Operating instructions	64
Tyre load capacity in special applications	65
Construction vehicle operations	66
Technical Data – EM (OTR) - Crossply Tyres	70

Rims and accessories	
Explanations and operating conditions for rims	75
Rims for industrial vehicles	77
Tapered base rims to DIN 7820 requirements for commercial vehicles and industrial trucks	78
Semi drop centre rims for commercial, all-purpose and earth-moving vehicles	79
Rims for earth-moving equipment	80
Well-base rims for light commercial and agricultural vehicles	81
Well-base rims for light commercial vehicles symmetrical and asymmetrical versions	82
Drop centre rims for Implement-, MPT- and Sand tyres	83
Recommended minimum dual spacing for twin tyres	84
Rims for press-on bands	86
Rims for press-on bands (metric sizes) with cylindrical or tapered base design	88
Rims for press-on bands (inch sizes) with cylindrical or tapered base design	90
Rims for press-on bands (metric sizes) with cylindrical or tapered base design	90
Valve accessories	92
Valves for tubes	93
Rubber valves for tubeless fitting	93
Screw-on angled valves with turning plate	94
Maintenance and care	
Regrooving of CSE-tyres	95
Fitting and removal	
Fitting and removal of CSE tyres	97
Fitting and removal using an SE Unimount	98
Fitting and removal using a 4-claw press	99
Fitting and removal using a plate press	100
Additional tools to further facilitate tyre fitting using a 4-claw or plate press	102
Set of removal rings	103
Fitting and removal of CSEasy	104
Fitting and removal of CSE tyres with SIT® type base	106
Fitting and removal of press-on bands with cylindrical base	108
Continental press-on bands – Fitting instruction for tapered base type	112
Service	113

On the following pages we have compiled comprehensive technical data and related information regarding tyres and accessories with the greatest care and as completely as possible according to the present status in development.

If particularly important decisions are to be made on the basis of information given in this guide, further data covering relevant standards such as ETRTO*) and DIN, plus the WdK**) Guidelines can also be consulted. Additionally, special information can of course always be obtained from us at the following address:

Continental AG
P.O. Box 169
D-30001 Hanover (Germany)

The data given in this guide is based on **average operating conditions as are normally found in Central Europe.**

For operating conditions which differ from these, please contact us.

The tyre sizes given here are not always identical to the ones available in the size range.

In this guide tyres which have been specially developed for industrial vehicles are referred to as Industrial tyres.

Warning

The following instructions must be observed if vehicle safety is to be guaranteed. This applies above all to instructions regarding tyre pressure. Failure to comply with these instructions could result in tyre damage that may lead to tyre failure under certain circumstances. And blow-outs can cause traffic accidents involving damage to property and/or personal injury.

*) ETRTO = THE EUROPEAN TYRE
AND RIM TECHNICAL ORGANISATION, BRÜSSELS

**) WdK = Wirtschaftsverband der
deutschen Kautschukindustrie e.V., Frankfurt.
(Association of the German Rubber Industry, Frankfurt)

Units of measurement and definitions (DIN 70020)

The technical specifications given in the tables generally comply with international ETRTO and DIN standards.

Additional information, such as further tyre sizes or versions, together with the static radius, is provided in compliance with DIN or with WdK-Guidelines.

Lengths

are given in millimetres (mm).

Tyre pressure in “bar”

(Tyre inflation) is given as an overpressure in bar and refers to the cold tyre.

Tyre pressure in “kPa”

(Tyre inflation).

Max. outer diameter of tyre in service

is the maximum diameter permitted in the tread centre as a result of **permanent** growth during tyre use.

Max. operational width

is the maximum permitted width. It includes scuff ribs, decorative ribs, tyre markings, and **permanent** growth during use.

Static radius

is the distance from the stationary tyre centre level to the ground.

Actual value

is the actual measurement of a Continental tyre.

The rolling circumference

is the road distance covered by a point on the tread during a single rotation of the wheel.

Control of measurements

on the fitted and inflated tyre with calibration tyre pressure according to DIN 70020, Sheet 5.

Loadcapacities

are given in kgs (weight in the sense of a mass).

CSE tyres

should always be interchangeable with pneumatic tyres.

The maximum measurements are, therefore to be taken when designing the fitting clearance.

The effective outer diameter of CSE tyres is approx. 2% smaller than that of pneumatic tyres. However, since the degree of deflection is less, the static radius r_{stat} is approximately the same. Vehicle designers should bear in mind the **maximum values** for tyre outer diameter and width when planning the **wheel space of a vehicle**, if standard approved tyres are to fit without any restrictions. Should this by way of exception not be possible the safety risk.

Tyre designations

In the course of development a variety of designations for **pneumatic tyres of vehicles** have been introduced. Even today various designations are in concurrent use.

CSE-tyres bear the same designation as pneumatic cross-ply tyres, with the added indication of the rim width.

Also, the word "SOLID" can be added to the size designation.

The table below gives a summary of the tyre designations and their meaning:

Tyre group	Designation example			Example contains ref. for				
	Tyre ⁻¹⁾ size	PR ⁻²⁾ value	Operat ⁻³⁾ code	Outer dia A	Tyre width B	H:B %	Rim dia. d	Rim width b
Pneumatic tyres	7.00-12	14	-	-	7"	-	12"	-
	7.00 R 12	16	136 A5	-	7"	-	12"	-
	23x5	6	-	23"	5"	-	-	-
	18x7-8	14	-	18"	7"	-	8"	-
	18x7 R 8	16	-	18"	7"	-	8"	-
	180/70 R 8	16	125 A 5	-	180 mm	70	8"	-
	250-15	18	125 A 5	-	250 mm	-	15"	-
	355/65-15	24	-	-	355 mm	65	15"	-
CSE tyres	18x7-8/4.33 SOLID		125 A	18"	7"	-	8"	4.33
Press-on bands	200/75-100	-	-	200 mm	75 mm	-	100mm	-
	16x6x10½	-	-	16"	6"	-	10½"	-

1) "-" = cross-ply design; R = radial design

2) PR = load capacity category

3) Operational code = Load Index (LI) and Speed Symbol (SSY)

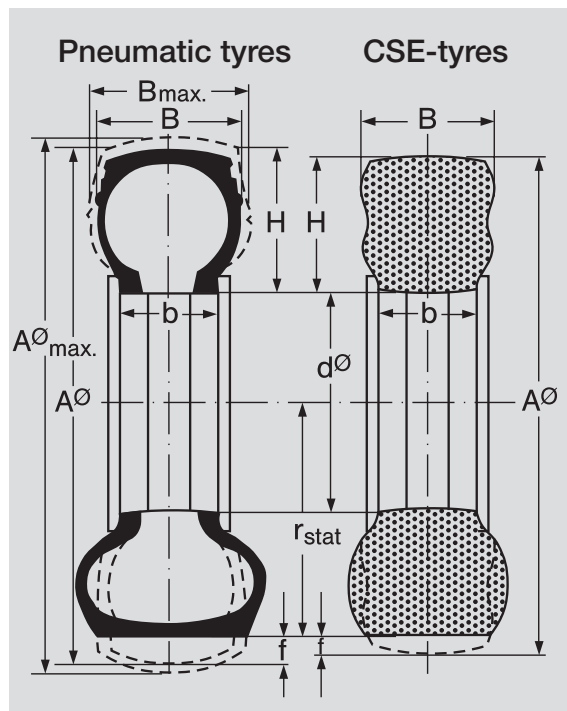

- $A\emptyset$ = tyre outer dia.
 $A\emptyset_{max.}$ = max. outer diameter of tyre in service
 B = cross-sectional width
 $B_{max.}$ = maximum operational width
 H = tyre height
 $d\emptyset$ = rim diameter
 b = rim width
 f = deflection under load
 $r_{stat.}$ = static radius
 $H:B$ = aspect ratio

SSY	Reference-speed	
	km/h	mph
A 1	5	3
A 2	10	6
A 3	15	9
A 4	20	12
A 5	25	16
A 6	30	19
A 7	35	22
A 8	40	25
B	50	31
C	60	37
D	65	40
E	70	44
F	80	50
G	90	56
J	100	62
K	110	68
L	120	75
M	130	81
N	140	87
P	150	93

In the past the tyre load capacity category was indicated only by a PR value.

For industrial radial, MPT and truck tyres there is an increasing use of a number-letter code for accurate tyre designation.

The load capacity is given as a Load Index (LI) – see the table on next page – for the relevant reference speed.

The reference speed is indicated in the form of a Speed Symbol (SSY) – see table (left).

Load-Indices (LI)

LI	kg	LI	kg	LI	kg	LI	kg	LI	kg
19	77,5	59	243	99	775	139	2430	179	7750
20	80	60	250	100	800	140	2500	180	8000
21	82,5	61	257	101	825	141	2575	181	8250
22	85	62	265	102	850	142	2650	182	8500
23	87,5	63	272	103	875	143	2725	183	8750
24	90	64	280	104	900	144	2800	184	9000
25	92,5	65	290	105	925	145	2900	185	9250
26	95	66	300	106	950	146	3000	186	9500
27	97,5	67	307	107	975	147	3075	187	9750
28	100	68	315	108	1000	148	3150	188	10000
29	103	69	325	109	1030	149	3250	189	10300
30	106	70	335	110	1060	150	3350	190	10600
31	109	71	345	111	1090	151	3450	191	10900
32	112	72	355	112	1120	152	3550	192	11200
33	115	73	365	113	1150	153	3650	193	11500
34	118	74	375	114	1180	154	3750	194	11800
35	121	75	387	115	1215	155	3875	195	12150
36	125	76	400	116	1250	156	4000	196	12500
37	128	77	412	117	1285	157	4125	197	12850
38	132	78	425	118	1320	158	4250	198	13200
39	136	79	437	119	1360	159	4375	199	13600
40	140	80	450	120	1400	160	4500	200	14000
41	145	81	462	121	1450	161	4625	201	14500
42	150	82	475	122	1500	162	4750	202	15000
43	155	83	487	123	1550	163	4875	203	15500
44	160	84	500	124	1600	164	5000	204	16000
45	165	85	515	125	1650	165	5150	205	16500
46	170	86	530	126	1700	166	5300	206	17000
47	175	87	545	127	1750	167	5450	207	17500
48	180	88	560	128	1800	168	5600	208	18000
49	185	89	580	129	1850	169	5800	209	18500
50	190	90	600	130	1900	170	6000	210	19000
51	195	91	615	131	1950	171	6150	211	19500
52	200	92	630	132	2000	172	6300	212	20000
53	206	93	650	133	2060	173	6500		
54	212	94	670	134	2120	174	6700		
55	218	95	690	135	2180	175	6900		
56	224	96	710	136	2240	176	7100		
57	230	97	730	137	2300	177	7300		
58	236	98	750	138	2360	178	7500		

Operating instructions DIN 7811, WdK-Guideline 211, WdK-Guideline 153, ETRTO

Load capacity. When determining the minimum tyre size necessary for any particular wheel position of a vehicle, the approved load and the maximum design speed of the vehicle must always be used as a basis.

Tyre pressure. The tyre pressures given in the tables are minimum tyre pressures and should be used only as a guide.

For special operating conditions specific tyre pressures can be recommended.

All tyre pressures refer to the “cold” tyre which has been standing outdoors for several hours, not exposed to intense sunlight.

Rims. Only the rims indicated are approved for equipping new vehicle series. In the following tables the recommended rim is printed in bold type.

Wheels. The load capacity must be adequate in all cases.

New

Tubeless Sealing Ring – TSR

Greater safety and mobility

The TSR enables tubeless industrial tyres to be fitted on to standard industrial tyre rims that, because of their design, would normally require an inner tube and bead flap. The TSR consists of a rubber ring with an integrated tyre valve. This rubber ring fits on the cylindrical part of the rim between the two tyre beads and provides an airtight seal for the air chamber without the need for an inner tube and bead flap.



Drawbacks of tube type tyres

- Rapid pressure loss in the case of tyre failure
- Risk of damage to freight and vehicle
- Vehicle is immediately out of action and work is interrupted
- Risk of valve being torn out

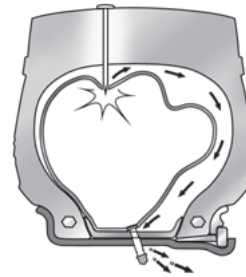

Advantages of tubeless tyres

- No sudden pressure loss in the case of tyre failure
The vehicle remains operational and can still be driven
There are no sudden load shifts, which means greater vehicle stability
- If the tyre turns on the rim, this is not critical
- Low aspect ratio tyres are more durable
- Faster, easier tyre fitting
- No need for a cover under the valve hole to prevent the bead flap from being forced out
- Fewer components than with tube type tyres

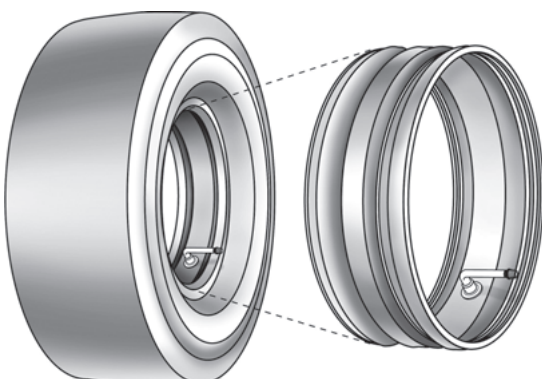
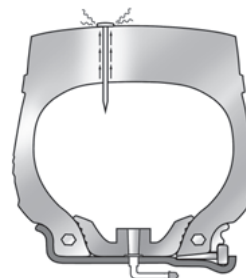

Important note

TSRs may only be used with those Continental industrial tyres designed to accommodate them. Such tyres carry the following reference on the sidewall: "This tyre is compatible with the Continental TSR system".

Tyres carrying the reference that they are compatible with TSRs can also be used with an inner tube and bead flap.

The TSR system is not suitable for centre-split rims.

Only new TSRs (maximum age 3 years) should ever be used.

The TSR must only be used once.

Tyre size	Rim	TSR item designation	TSR item no.
5.00R8	3.00 D-8	TSR 3.00TL8 TL CO	0793017
125/75R8	3.00 D-8 3.25 I 8	TSR 3.00/3.25TL8 TL CO	0793002
150/75R8	4.33 R-8	TSR 4.33TL8 TL CO	0793003
180/70R8			
6.00R9	4.00 E-9	TSR 4.00TL9 TL CO	0793004
6.50R10	5.00 F-10 5.50 F-10	TSR 5.00/5.50TL10 TL CO	0793005
225/75R10	6.50 F-10	TSR 6.50TL10 TL CO	0793007
7.00R12	5.00 S-12	TSR 5.00TL12 TL CO	0793001
250/75R12	8.00 G-12	TSR 8.00TL12 TL CO	0793011
7.00R15	5.5-15	TSR 5.50TL15 TL CO	0793006
7.50R15	6.0-15 6.5-15	TSR 6.00/6.50TL15 CO	0793008
8.25R15	6.5-15	TSR 6.50TL15 CO	0793000
225/75R15	7.0-15	TSR 7.00TL15 CO	0793009
250/70R15	7.0-15 7.5-15	TSR 7.00/7.50TL15 CO	0793015
315/70R15	8.0-15	TSR 8.00TL15 TL CO	0793012
355/65R15	9.75-15	TSR 9.75TL15 TL CO	0793014
10.00R20	7.5-R20	TSR 7.50TL20 TL CO	0793010
11.00R20	8.0-20	TSR 8.00TL20 CO	0793013
12.00R20	8.0-20 8.5-20	TSR 8.00/8.50TL20 CO	0793016

Industrial Pneumatic Tyres

General Characteristics

The construction of Industrial Pneumatic Tyres ensures excellent ride comfort on unpaved ground even at high speeds. Also recommended for use on public roads.

Special applications by construction

Radial:

- extraordinary high mileage
- enhanced ride comfort
- low rolling resistance
- very good traction
- electroconductive

Crossply:

- enhanced stability (on paved grounds)
- resistant to sidewall damage
- good traction

Suitable vehicles:

- indoor service trailers
- forklift trucks
- heavy-duty transport vehicles
- platform trucks
- industrial tractors
- airport vehicles
- self-powered lift vehicles
- side-loading forklifts

General applications

- logistics centres
- seaports
- industry
- airports
- dockyards

Core features

Customer benefits

ConRad HT

Radial - Industrial Pneumatic Tyres



Tougher for longer service in heavy duty applications, with exclusive asymmetrical half track tread giving extra benefits in twin fitments and steered wheels.

- | | |
|------------------------|--|
| • solid shoulder | ➡ steady grip on twin fitments and steering-wheels |
| • extra deep profile | ➡ long service life for low operating costs |
| • robust belted design | ➡ reduced tread damage |

New

Core features

Customer benefits

CONRAD

Radial Industrial Pneumatic



Optimised tread pattern in 6 sizes

- 7.00R12 ConRad
- 165R13 ConRad
- 8.25R15 ConRad
- 250/70R15 ConRad
- 315/70R15 ConRad
- 12.00R20 ConRad

- New tread pattern design with 3 circumferential ribs
- Sturdy radial casing
- Reduced driving noise
- Even wear pattern
- Optimum suspension and absorption
- High durability and mileage

To achieve an optimum mile age, the following fitting recommendation should be observed:

- For twin fitments, the patterned tread sides should be turned towards each other. This avoids roof-shaped wear that can easily occur for twin tyre fitments.
- For twin fitments, tyres should be fitted with the tread bars facing each other but arranged in offset positions.
- Conical wear – which is frequently observed on steering wheels – can be reduced by selective fitting, i.e. the smooth side should be fitted on the shoulder that is subject to more rapid wear.
- Normally this will be the outer side of the vehicle. This fitting procedure has another advantage: the smooth outside shoulder means that tread blocks are not chunked off the shoulder if the tyre hits an obstacle.

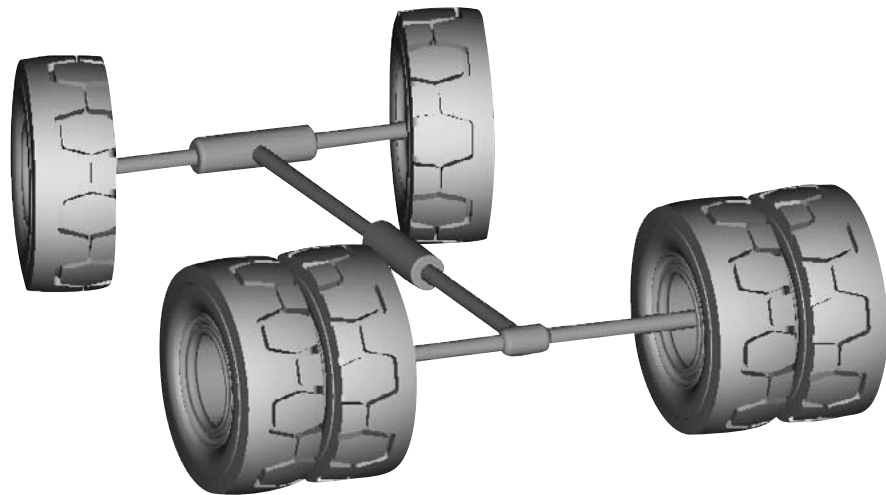

Core features

Customer benefits

IC 80 Extra Deep

Radial - Industrial Pneumatic Tyres



Greater damage resistance, designed for the toughest applications

- extra deep profile
 - robust belted construction
- ➡ high mileage performance
 - ➡ reduces tread damage

IC 70

Radial - Industrial Pneumatic Tyres



The universal tyre for all wheel positions.

- good suspension
 - even ground pressure
 - robust belted construction
- ➡ excellent ride comfort
 - ➡ good grip and traction
 - ➡ reduces tread damage

Tyre design: All-steel construction

Steel cord casing and reinforcing multiply steel cord belt. The flat tread shape means an even pressure distribution and thus even wear across the entire tread width.

Radial tyres are conductive

The leakage resistance of $<10^6$ ohm hence complies with WDK guideline 110. Longer contact with swelling media/oil/solvent reduces conductability. Electric contact between tyre and rim must be ensured.

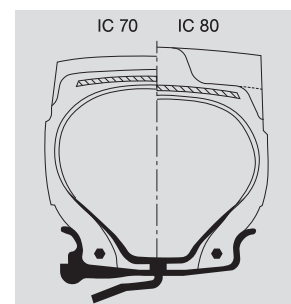

Size range, specifications and tyre load capacities ConRad HT

Tyre					Rim	Tube and valve	Flap	Tyre dimensions max. in service			
Size	ConRad HT CONRAD	PR	Code					Standard value		Actual value	
			LI	GSY				width	outer dia.	width + 1%	outer dia. ± 1%
acc. o ETRTO											
6.00 R 9 TL	•	12	121	A 5 entspricht 25 km/h	4.00 E-9	6.00-9/21 x 8-9 41.5 G 70/60 D	100-9	165	551	160	541
6.50 R 10 TL	•	14	128		5.00 F-10	6.50/7.50-10 41.5 G 70/60 D ²⁾	130-10	182	600	176	591
225/75 R 10 TL	•	20	142		6.50 F-10	23 x 9-10 225/75-10/60 D	180-10	239	606	227	597
7.00 R 12 TL	•	16	136		5.00 S-12	7.00-12 60 D/75 D	130-12	198	685	194	677
250/75 R 12 TL	•	20	152		8.00 G 12	27 x 10-12 250/75-12/60 D	220-12	274	695	264	687
165 R 13 TL	•	-	102/ A6		4.50 x 13B	-	-	174	606	167	599
7.50 R 15 TL	•	16	146		6.0-15	7.50-15 8.25-15 75 D/105 D 75 D-74	170-15 ⁵⁾	218	787	211	776
					6.5-15		170-15 ⁵⁾	223	787	216	776
8.25R 15 TL	•	18	153		6.5-15		170-15 ⁵⁾	241	853	238	842
225/75 R 15 TL (28 x 9 R 15)	•	16	149		7.0-15	28 x 9-15 250/70-15 75 D-74 95 D-74	190-15 ⁵⁾	245	732	221	728
250/70 R 15 TL (250 R 15)	•	18	153		7.0-15		190-15 ⁵⁾	264	745	240	743
					7.5-15		190-15 ⁵⁾	269	745	245	743
315/70 R 15 TL (300 R 15)	•	22	165		8.0-15	300-15/ 355/65-15 95 D-74/ 95 D-Z	240-15 ⁵⁾	323	840	304	830
355/65 R 15 TL	•	-	175		9.75-15		240-15 ⁵⁾	372	861	332	835
10.00 R 20 TL (290/95 R 20)	•	18	166		7.5-20	10.00-20 127 D-Z	190-20 ⁵⁾	309	1073	278	1064
11.00 R 20 TL (300/95 R 20)	•	16	169		8.0-20	11.00/12.00-20 127 D-Z	220-230 ⁵⁾	309	1104	286	1100
12.00 R 20 TL (330/95 R 20)	•	20	176		8.5-20	11.00/12.00-20 127 D-Z	230-20 ⁵⁾	338	1144	311	1140

1) Static radius (actualvalue): A: for load capacity on other vehicles at 16 mph (25km/h), B: for load-wheel capacity on forklifts at 16 mph (25km/h).

2) Use flap with centre valve hole.

3) Other vehicles, e.g. platform trucks, trailers, tractors, straddle carriers, forklifts without counterweight etc.

Static ¹⁾ radius		Tyre Pressure		Reifentragfähigkeit						Size
Actual value ± 2,5 %				Stationary	on other vehicles ³⁾ at max. speed (mph)			on fork lifts max. 25 mph		
A	B	bar	kHa		6	16	25	Load wheel	Steered wheel ⁴⁾	
acc. to ETRTO										
251	246	10,0	1000	2190	1885	1450	1245	1885	1450	6.00 R 9 TL
270	266	10,0	1000	2720	2340	1800	1605	2340	1800	6.50 R 10 TL
268	262	10,0	1000	4005	3445	2650	2360	3445	2650	225/75 R 10 TL
313	307	10,0	1000	3385	2915	2240	1995	2915	2240	7.00 R 12 TL
309	300	10,0	1000	5365	4615	3550	3160	4615	3550	250/75 R 12 TL
-	-	4,5	450	-	-	30 km/h 850		-	-	165 R 13 TL
360	353	10,0	1000	4530	3900	3000	2670	3900	3000	7.50 R 15 TL
-	-	10,0	1000	4530	3900	3000	2670	3900	3000	
388	380	10,0	1000	5515	4745	3650	3250	4745	3650	8.25R 15 TL
334	327	10,0	1000	4910	4225	3250	2895	4225	3250	225/75 R 15 TL (28 x 9 R 15)
339	330	10,0	1000	5515	4745	3650	3250	4745	3650	250/70 R 15 TL (250 R 15)
339	330	10,0	1000	5515	4745	3650	3250	4745	3650	
371	359	10,0	1000	7780	6695	5150	4585	6695	5150	315/70 R 15 TL (300 R 15)
365	347	10,0	1000	10420	8970	6900	-	8970	6900	355/65 R 15 TL
492	448	10,0	1000	8000	6890	5300	4715	6890	5300	10.00 R 20 TL (290/95 R 20)
507	497	10,0	1000	8760	7540	5800	5160	7540	5800	11.00 R 20 TL (300/95 R 20)
522	513	10,0	1000	10720	9230	7100	6320	9230	7100	12.00 R 20 TL (330/95 R 20)

4) The steering wheel load capacities 16 mph (25km/h) are to be applied for tyres on side-loading forklift trucks, straddle carriers and portal lift trucks speed of 16 mph (25km/h).

5) The use of a valve shield is recommended.

The minimum dual spacing is indicated on page 84.

- available

Size range, specifications and tyre load capacities

Tyre					Rim	Tube and valve	Flap	Tyre dimensions max. in service				
Size	IC 70	IC 80	PR	Code				Standard value		Actual value		
				LI				SSY	width	outer dia.	IC 70/IC 80 width + 1%	outer dia. ± 1%
acc. to ETRTO												
5.00 R 8 TL	•	• ⁴⁾	10	111	A 5 = 25 km/h	3.00 D-8	5.00-8 41.5 G 70	85-8 85-8	136 136	476 476	132 129	461 465
125/75 R 8 TL (15 x 4½ R 8)	•		12	100		3.00 D-8 3¼ I-8	15 x 4¼-8/ 125/75-8 43 D-60	85-8 85-8	126 129	392 392	120 124	384 384
150/75 R 8 TL (16 x 6 R 8)	•		16	113		4.33 R-8	16 x 6-8/ 18 x 7-8 41.5 G 70 60 D	115-8	160	439	150	425
180/70 R 8 TL (18 x 7 R 8)	•	• ⁴⁾	16	125				115-8	182	465	171	452
6.00 R 9 TL	•	• ⁴⁾	12	121				115-8	182	465	168	465
6.50 R 10 TL	•	• ⁴⁾	14	128				4.00 E-9	6.00-9/ 21 x 8-9 41.5 G 70/60 D	100-9 100-9	165 165	551 551
225/75 R 10 TL (23 x 9 R 10)	•	• ⁴⁾	20	142		5.00 F-10	6.50/7.50-10	130-10	182	600	180	577
7.00 R 12 TL	•	• ⁴⁾	16	136 136		5.50 F-10	41.5 G 70/60 D ²⁾	130-10	187	600	176	586
250/75 R 12 TL (27 x 10 R 12)	•	• ⁴⁾	20	152		6.50 F-10	23 x 9-10/ 225/75-10/60 D	180-10	239	606	228	587
7.00 R 15 TL	•		14	140		5.00 S-12	7.00-12 60 D/75 D	130-12 130-12	198 198	685 685	193 190	660 673
7.50 R 15 TL	•	• ⁴⁾	16	146		8.00 G-12	27x10-12/ 250/75-12/60 D	220-12	274	695	260	678
8.25 R 15 TL	•	• ⁴⁾	18	153		5.5-15	7.00-15/200-15 75 D-74	170-15 ⁶⁾	203	761	197	737
225/75 R 15 TL (28 x 9 R 15)	•	• ⁴⁾	16	149		6.0-15	7.50-15/ 8.25-15	170-15 ⁶⁾ 170-15 ⁶⁾	218 224	787 787	211 207	772 773
250/70 R 15 TL (250 R 15)	•	• ⁴⁾	18	153		6.5-15	75 D/105 D/ 75 D-74	170-15 ⁶⁾ 170-15 ⁶⁾	241 241	853 853	237 234	826 837
315/70 R 15 TL (300 R 15)	•		22	165		7.0-15	28 x 9-15/ 250/70-15	190-15 ⁶⁾	245	732	217	719
						7.0-15	75 D-74	190-15 ⁶⁾	264	745	240	734
						7.5-15	95 D-74	190-15 ⁶⁾	269	745	245	755
						8.0-15	300-15/355/65-15/ 95 D-74/95 D-Z	240-15 ⁶⁾	323	840	305	827

1) Static radius (actual value): A: for load capacity on other vehicles at 16 mph (25km/h), B: for load-wheel capacity on forklifts at 16 mph (25km/h).

2) Use flap with centre valve hole.

3) Other vehicles, e.g. platform trucks, trailers, tractors, straddle carriers, forklifts without counterweight etc.

4) Maximum speed for IC 40 Extra Deep tread pattern = 25 mph (40 km/h)

Static ¹⁾ radius		Reifentragfähigkeit										Size
Actual value ± 2,5 %		Tyre Pressure		Stationary	on other vehicles ³⁾ at max. speed (mph)				on fork lifts max. 16 mph			
A	B	bar	kPa		6	16	25 ⁵⁾	31 ⁵⁾	Load wheel ⁷⁾	Steered wheel ⁵⁾		
acc. to ETRTO												
209	204	10,0	1000	1650	1420	1090	975	920	1420	1090	5.00 R 8 TL	
211	206	10,0	1000	1650	1420	1090	975	920	1420	1090		
174	170	10,0	1000	1210	1040	800	715	675	1040	800	125/75 R 8 TL (15 x 4 1/2 R 8)	
174	170	10,0	1000	1210	1040	800	715	675	1040	800		
194	189	10,0	1000	1740	1495	1150	1025	970	1495	1150	150/75 R 8 TL (16 x 6 R 8)	
200	194	10,0	1000	2495	2145	1650	1470	1390	2145	1650	180/70 R 8 TL (18 x 7 R 8)	
204	197	10,0	1000	2495	2145	1650	1470	1390	2145	1650		
242	236	10,0	1000	2190	1885	1450	1295	1220	1885	1450	6.00 R 9 TL	
246	240	10,0	1000	2190	1885	1450	1295	1220	1885	1450		
260	253	10,0	1000	2720	2340	1800	1605	1515	2340	1800	6.50 R 10 TL	
264	257	10,0	1000	2720	2340	1800	1605	1515	2340	1800		
256	246	10,0	1000	4005	3445	2650	2360	2230	3445	2650	225/75 R 10 TL (23 x 9 R 10)	
300	292	10,0	1000	3385	2915	2240	1995	1885	2915	2240	7.00 R 12 TL	
307	299	10,0	1000	3385	2915	2240	1995	1885	2915	2240		
299	287	10,0	1000	5365	4615	3550	3160	–	4615	3550	250/75 R 12 TL (27 x 10 R 12)	
338	331	10,0	1000	3775	3250	2500	2225	2100	3250	2500	7.00 R 15 TL	
348	340	10,0	1000	4530	3900	3000	2670	2520	3900	3000		
352	343	10,0	1000	4530	3900	3000	2670	2520	3900	3000	8.25 R 15 TL	
374	364	10,0	1000	5515	4745	3650	3250	3070	4745	3650		
383	373	10,0	1000	5515	4745	3650	3250	3070	4745	3650		
327	315	10,0	1000	4910	4225	3250	2895	–	4225	3250	225/75 R 15 TL (28 x 9 R 15)	
331	322	10,0	1000	5515	4745	3650	3250	3070	4745	3650	250/70 R 15 TL (250 R 15)	
337	327	10,0	1000	5515	4745	3650	3250	3070	4745	3650		
360	348	10,0	1000	7780	6695	5150	4585	–	6695	5150	315/70 R 15 TL (300 R 15)	

5) The steering wheel load capacities 16 mph (25km/h) are to be applied for tyres on side-loading forklift trucks, straddle carriers and portal lift trucks speed of 16 mph (25km/h).

6) The use of a valve shield is recommended.

7) The load wheel load capacity is based on an average speed of 6 mph
The minimum dual spacing is indicated on page 84.

• available

Core features

Customer benefits

IC 40 Extra Deep

Crossply - Industrial Pneumatic Tyres



Designed for tough applications in gruelling conditions.

- extra deep profile
 - optimal tread design
 - enhanced sidewall
- ➡ long service life for low operating costs
 - ➡ good traction
 - ➡ damage resistant stability

IC 10/12

Crossply - Industrial Pneumatic Tyres



The universal tyre for all wheel positions.

- proven tread pattern
 - good suspension
- ➡ good traction
 - ➡ good ride comfort

Tyre cross-sections IC 40 Extra Deep and IC 10 in comparison:

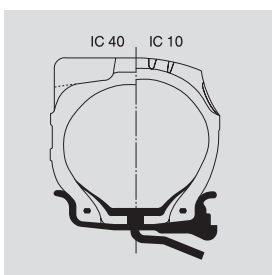

Hints

All listed industrial pneumatic tyres are of the tube type (TT). They must be fitted with an inner tube and bead flap.

Core features

Customer benefits

IC 30

Crossply - Industrial Pneumatic Tyres



Designed for unpaved surfaces. This profile is available in sizes 23x9-10 (225/75-10) and 27x10-12 (250/75-12).

- strong lugs constructed from wear-resistant compound
 - open profile design
- ⇒ good mileage
- ⇒ good traction

IC 35/IC 36

Crossply - Industrial Pneumatic Tyres



Designed for trailers. This profile is available in sizes 3.00-4 (IC 35) or 15x4-8. (IC 36)

- circumferential tread pattern
 - flat solid tread pattern
- ⇒ safer operation with good grip and stability
- ⇒ excellent steering characteristics



Industrial crossply tyres are also available in an electrostatically effective version, where the leakage resistance of $<10^6$ ohm hence complies with WdK-Guideline 110, provided that the tyres are used intended. Prolonged contact with media that cause swelling (such as oil or solvents) reduces the conductivity. Electric contact between tyre and rim must be ensured.

Size range, specifications and tyre load capacities

Tyre					Rim	Tube and valve	Flap	Tyre dimensions max. in service				
Size	Tread		PR	Code pattern				Standard value max. in service		Actual value		
	IC10 IC12	IC40		LI				SSY	width	outer-dia.	width + 1%	outer-dia. ± 1%
acc. to ETRTO												
3.00-4	• IC35		4	51	A 5 = 25 km/h	2.10-4	3.00/4.00-4/ 260 X 85 38 G 90/28 G-90	– –	87 87	260 260	83 82	248 252
4.00-4	•		6	77		2.50 C-4		–	116	318	107	312
4.00-8	• •		6	90		3.00 D-8	4.00-8 41.5 G-70 38 G 11.5	85-8	121	422	114	418
			10	97				85-8	124	422	114	418
5.00-8	•	•	8	106		3.00 D-8	5.00-8 41.5 G 70	85-8	143	476	132	469
15 x 4½-8 (125/75-8)	IC36		12	100		3.00 D-8	15 x 4½-8/ 25/75-8 43 D-60	85-8	132	393	123	378
16 x 6-8 (150/75-8)	•		16	113		4.33 R-8	16 x 6-8/ 18 x 7-8 60 D 41.5 G-70	115-8	164	434	143	422
18 x 7-8 (180/70-8)	• •		16	125				115-8	187	471	163	461
								115-8	187	471	171	471
6.00-9	•	•	12	121		4.00 E-9	6.00-9/ 21 x 8-9	100-9 100-9	173 173	551 551	158 160	539 542
21 x 8-9 (200/75-9)	• •	•	14	131		6.00 E-9	41.5 G 70 60 D	150-9	216	546	194	519
			16	134				150-9	216	546	195	533
6.50-10	• •		14	128		5.00 F-10	6.50/7.50-10 41.5 G 70 60 D ²⁾	130-10	191	600	174	581
						5.50 F-10		130-10	191	600	174	592
130-10	197	600	174	581								
130-10	197	600	191	592								
7.50-10 □	•		12	133		5.50 F-10		130-10	224	658	204	616
23 x 9-10 (225/75-10)	• • • •	IC30	14	134		6.50 F-10	23 x 9-10/ 225/75-10 60 D	180-10	243	607	218	575
			20	142				180-10	243	607	220	591
			20	142				180-10	243	607	218	575
			20	142	180-10			243	607	218	587	
7.00-12	• •	• •	14	134	5.00 S-12	7.00-12 75 D/60 D	130-12	207	685	188	669	
			16	136			130-12	207	685	191	669	
27 x 10-12 (250/75-10)	• • •	IC30	14	143	8.00 G-12	27 x 10-12 250/75-12 60 D	220-12	275	704	243	675	
			20	152			220-12	275	704	255	671	
			20	152			220-12	275	704	243	685	
21 x 4	•		4	98	3.11 F-13	21 x 4/	100-13	131	582	120	579	
22 x 4½	• •		4	101	3.11 F-13	22 x 4½	100-13	143	613	130	586	
					3.75 P-13	41.5 G 70/90	100-13	149	613	136	586	

- 1) Static radius (actualvalue): A: for load capacity on other vehicles at 16 mph (25km/h), B: for load-wheel capacity on forklifts at 16 mph (25km/h).
 2) Use flap with centre valve hole.
 3) Other vehicles, e.g. platform trucks, trailers, tractors, straddle carriers, forklifts without counterweight etc.
 □ to be discontinued

Static ¹⁾ radius		Tyre pressure		Tyre load capacity (kg)							Size
Actual value ± 2,5 %				Stationary	on other vehicles ³⁾ at max. speed (mph)				on fork lifts max. 16 mph		
A	B	bar	kPa		6	16	25 ⁴⁾	31 ⁴⁾	Load wheel ⁵⁾	Steered wheel ⁴⁾	
acc. to ETRTO											
116	113	6,75	675	295	255	195	175	165	–	–	3.00-4
116	113	6,75	675	295	255	195	175	165	–	–	
140	136	8,0	800	620	535	412	365	345	535	412	4.00-4
191	188	8,0	800	905	780	600	535	505	780	600	4.00-8
191	188	10,0	1000	1100	950	730	650	615	950	730	
213	208	8,25	825	1435	1235	950	845	800	1235	950	5.00-8
177	174	10,0	1000	1210	1040	800	710	670	1040	800	15 x 4½-8 (125/75-8)
196	192	10,0	1000	1740	1495	1150	1025	970	1485	1150	16 x 6-8 (150/75-8)
211	206	10,0	1000	2490	2145	1650	1470	1385	2145	1650	18 x 7-8 (180/70-8)
211	206	10,0	1000	2490	2145	1650	1470	1385	2145	1650	
245	240	10,0	1000	2190	1885	1450	1290	1220	1885	1450	6.00-9
245	240	10,0	1000	2190	1885	1450	1290	1220	1885	1450	
241	234	9,0	900	2945	2535	1950	1735	1640	2535	1950	21 x 8-9 (200/75-9)
241	234	10,0	1000	3200	2755	2120	1885	1780	2755	2120	
268	262	10,0	1000	2720	2340	1800	1600	1510	2340	1800	6.50-10
268	262	10,0	1000	2720	2340	1800	1600	1510	2340	1800	
268	262	10,0	1000	2720	2340	1800	1600	1510	2340	1800	
268	262	10,0	1000	2720	2340	1800	1600	1510	2340	1800	
291	284	8,0	800	3110	2680	2060	1835	1730	2680	2060	7.50-10 □
291	284	8,0	800	3110	2680	2060	1835	1730	2680	2060	23 x 9-10 (225/75-10)
268	260	7,0	700	3200	2755	2120	1885	1780	2755	2120	
268	260	7,0	700	3200	2755	2120	1885	1780	2755	2120	
268	260	10,0	1000	4000	3445	2650	2360	2225	3445	2650	
309	303	9,0	900	3200	2755	2120	1885	1780	2755	2120	7.00-12
309	303	10,0	1000	3380	2910	2240	1995	1880	2910	2240	
312	304	7,0	700	4115	3545	2725	2425	2290	3545	2725	27 x 10-12 (250/75-10)
312	304	7,0	700	4115	3545	2724	2425	2290	3545	2725	
312	304	10,0	1000	5360	4615	3550	3160	2980	4615	3550	
265	–	4,75	475	1130	975	750	670	630	–	–	21 x 4
278	–	4,0	400	1245	1075	825	735	695	–	–	22 x 4½
278	–	4,0	400	1245	1075	825	735	695	–	–	

4) The steering wheel load capacities 16 mph (25km/h) are to be applied for tyres on side-loading forklift trucks, straddle carriers and portal lift trucks speed of 16 mph (25km/h).

5) The use of a valve shield is recommended.

Size range, specifications and tyre load capacities

Tyre					Rim	Tube and valve	Flap	Tyre max. in service				
Size	Tread		PR	Code pattern				Standard value max. in service		Actual value		
	IC10 IC12	IC40		LI				SSY	width	outer dia.	width + 1%	outer dia. ± 1%
acc. to ETRTO												
23 x 5	•	•	6	113	A 5 = 25 km/h	3.75 P-13	23 x 5/25 x 6 60 D	100-13	167	654	154	633
									100-13	167	654	153
25 x 6	•	•	8	126		3.75 P-13		100-13	184	700	166	674
								100-13	184	700	171	675
7.00-15	•		12	138		5.5-15	7.00-15/ 200-15/75 D-74	170-15 [Ⓜ]	213	761	197	736
7.50-15 □	•	•	14	144		6.0-15	7.50/8.25-15 75 D/105 D	170-15 [Ⓜ]	229	787	210	774
			16	146		6.5-15		170-15 [Ⓜ]	234	787	208	760
8.25-15	•	•	18	153		6.5-15	75 D-74	170-15 [Ⓜ]	253	853	228	814
								170-15 [Ⓜ]	253	853	233	834
10.00-15 □	•		18	158		7.5-15	10.00-15 95 D-74	190-15 [Ⓜ]	297	936	278	879
200-15 □ (200/85-15)	•		12	139		5.0-15	7.00-15/200-15 75 D-74	170-15 [Ⓜ]	205	735	205	711
28 x 9-15 (225/75-15)	•	•	14	146		7.0-15	28 x 9-15/ 250/70-15	190-15 [Ⓜ]	233	721	211	701
								190-15 [Ⓜ]	233	721	222	712
250-15 (250/70-15)	•	•	18	153		7.0-15	75 D-74	190-15 [Ⓜ]	265	750	225	728
					190-15 [Ⓜ]			270	750	230	737	
300-15 (315/70-15)	•	•	22	165	7.5-15	95 D-74	190-15 [Ⓜ]	324	857	292	798	
							190-15 [Ⓜ]	324	857	293	803	
355/65-15	•	•	24	170	8.0-15	300-15/ 355/65-15	190-15 [Ⓜ]	372	861	339	802	
							190-15 [Ⓜ]	372	861	334	840	

1) Static radius (actual value): A: for load capacity on other vehicles at 16 mph (25 km/h), B: for load-wheel capacity on forklifts at 16 mph (25 km/h).

2) Other vehicles, e.g. platform trucks, trailers, tractors, straddle carriers, forklifts without counterweight etc.

□ to be discontinued

Static ¹⁾ radius		Tyre pressure		Tyre load capacity (kg)								Size
Actual value ± 2,5 %				Stationary	on other vehicles ²⁾ at max. speed (mph)				on fork lifts max. 16 mph			
A	B	bar	kPa		6	16	25 ³⁾	31 ³⁾	Load wheel ⁴⁾	Steered wheel ³⁾		
acc. to ETRTO												
295	290	5,25	525	1735	1495	1150	1025	965	1495	1150	23 x 5	
295	290	5,25	525	1735	1495	1150	1025	965	1495	1150		
313	307	6,5	650	2565	2210	1700	1515	1430	2210	1700	25 x 6	
313	307	6,5	650	2565	2210	1700	1515	1430	2210	1700		
346	340	8,25	825	3565	3070	2360	2100	1980	3070	2360	7.00-15	
357	350	9,25	925	4230	3640	2800	2490	2350	3640	2800	7.50-15 □	
357	350	10,0	1000	4530	3900	3000	2670	2520	3900	3000		
393	376	10,0	1000	5510	4745	3650	3250	3065	4745	3650	8.25-15	
393	376	10,0	1000	5510	4745	3650	3250	3065	4745	3650		
418	409	10,0	1000	6410	5525	4250	3785	3570	5535	4250	10.00-15 □	
337	330	8,5	850	3670	3160	2430	2165	2040	3160	2430	200-15 □ (200/85-15)	
329	322	10,0	1000	4380	3900	3000	2670	2520	3900	3000	28 x 9-15 (225/75-15)	
329	322	10,0	1000	4380	3900	3000	2670	2520	3900	3000		
340	333	9,5	950	5510	4745	3650	3250	3065	4745	3650	250-15 (250/70-15)	
340	333	9,5	950	5510	4745	3650	3250	3065	4745	3650		
383	857	10,0	1000	7775	6695	5150	4585	4325	6695	5150	300-15 (315/70-15)	
383	857	10,0	1000	7775	6695	5150	4585	4325	6695	5150		
383	373	10,0	1000	9060	7800	6000	5340	5040	7800	6000	355/65-15	
383	373	10,0	1000	9060	7800	6000	5340	5040	7800	6000		

3) The steering wheel load capacities 16 mph (25km/h) are to be applied for tyres on side-loading forklift trucks, straddle carriers and portal lift trucks speed of 16 mph (25km/h).

4) The use of a valve shield is recommended.

Solid tyres

General Characteristics

Solid Tyres are best for tough applications on slow vehicles or trailers with a high risk of impact and cut damage. They are extremely stable, puncture resistant and maintenance free. Solid tyres have a high load capacity and are extremely economical, ideal for all types of forklift trucks.

Special applications by construction

Super-Elastic:

- can be fitted on pneumatic-tyre rims
- clean tyres designed for minimum floor marking in dust sensitive applications
- robust sidewall
- easy to fit with SIT-retaining bead (only for SIT-Tyres)

Press-on Bands:

- high stability
- greater load capacity on smaller dimensions

Suitable vehicles

- forklift trucks
- indoor service trailers
- airport vehicles
- self-powered lift vehicles
- side-loading forklifts
- indoor tractors
- industrial tractors
- heavy-duty transport vehicles
- platform trucks

General applications

- logistic centres
- seaports
- industry
- food and pharmaceutical industry (Clean)
- airports
- dockyards
- steel industry

CSE tyres are press-on bands for fitting on pneumatic tyre rims and comply with international ETRTO and DIN standards.

Tyre construction

Tread area and sidewall protection

The tread area is exceptionally tough and wear resistant, giving the tyre a long service life (see footnote*).

Cushion compound

The whole structural and material content of the tyre guarantees not only good impact and vibration-damping properties but also allows rolling resistance**).

Tyre base

The tyre base is made of a hard tough compound in which the wire cores are embedded, ensuring the tyre sits firmly on the rim.

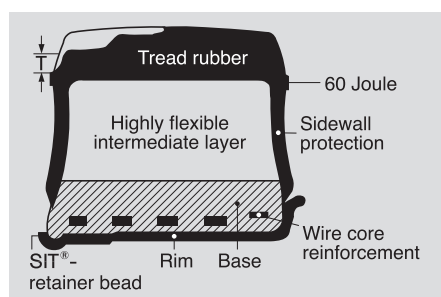

Tyre base and rim versions

Rims	Tyre bases
	<ul style="list-style-type: none"> • CSE ROBUST-SIT fits with the one-piece Lemmerz basic rim without taper, rim flange or locking rings.
	<ul style="list-style-type: none"> • CSE ROBUST for off-centre-split and centre-split rims.

CSE-ROBUST®-SIT®

On the CSE-ROBUST® the tread rubber protects the entire sidewall from external damage.

The tyre is therefore suitable for extremely arduous applications.

* The upper edge of the 60-Joule-indicator shows the maximum limit for wear and regrooving of the CSE-tyre. Account is to be taken of the envisaged service conditions when deciding on whether to regroove a tyre.

** Temperature build-up in CSE tyres is low due to their good rolling resistance, making the tyres capable of meeting high in-service demands. Damage due to heat, however, cannot always be excluded if the tyres are used for continuous operation (e.g. on a three-shift basis, long stretches at high loads or high speeds).

New

CSEasy innovation

CSEasy – Innovative. Fast. Easy.



With the innovation CSEasy Continental markets the top product all around in terms of economy, environmental awareness and complexity minimization. In every way this solid-rubber tire represents a revolution in simplicity. No mounting press at all is needed for the wheel/tire system, which includes an adapter between the tire and the rim.

Economy

- up to 40% more mileage*
- up to 6% reduced energy cost*
- less cost for fitment
- less cost for downtime

40 % reduction in rolling resistance saves 6 % in energy

Environmental awareness

- up to 6% less CO₂ emissions*
- Nitrosamine-free!
- free of highly aromatic oils!

(in accordance with EU-Guideline 2005/69/EG)

Fitting is not only possible without a press, but can also be carried out in situ on the vehicle using standard tools. This saves time when changing tyres and reduces complications, because fewer steps are involved e.g. replacement rims.

* Reference: mileage compared with SC15, rolling resistance, energy consumption and CO₂ emissions compared with the competition.

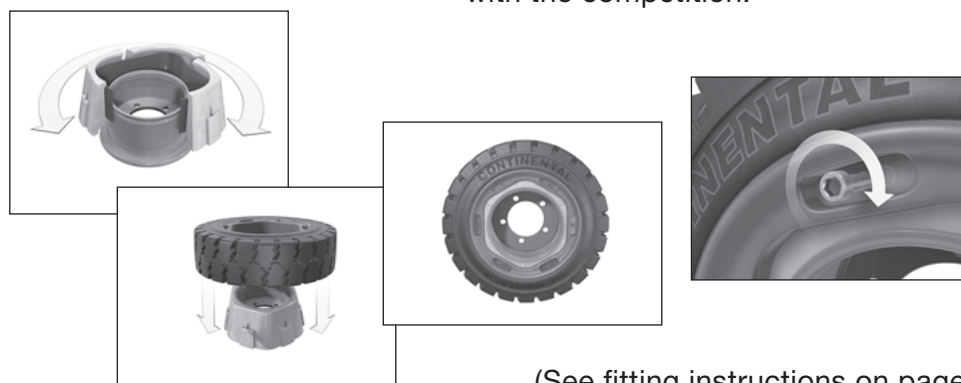

(See fitting instructions on page 104)

New

Superior technology – the SC 20



The SC 20 generation from Continental sets new standards in terms of economy and environmental compatibility. The outstanding characteristics of this innovative tyre format are impressive:

Significantly increased mileage, 30% reduced rolling resistance and considerable lower CO₂ emissions make the SC 20 an investment that pays for itself many times over. It is the latest in a perfect range of successful developments designed by engineers at Continental and comfortably confirms their position as suppliers of premium products. Make the most of these attractive benefits.

Economy

- 20% higher mileage*
- 5% less energy consumption*

Environmental awareness

- Significantly reduced vehicle CO₂ emissions – approx. 5%!
- Nitrosamine-free!
- Free of highly aromatic oils!
(in accordance with EU Guideline 2005/69/EG)

30 % reduction in rolling resistance
saves 4.5% in energy

* Reference: mileage compared with SC 15, rolling resistance, energy consumption and CO₂ emissions compared with the competition

SC 20 – the new features:



- Improved traction
 - Greater tread depth

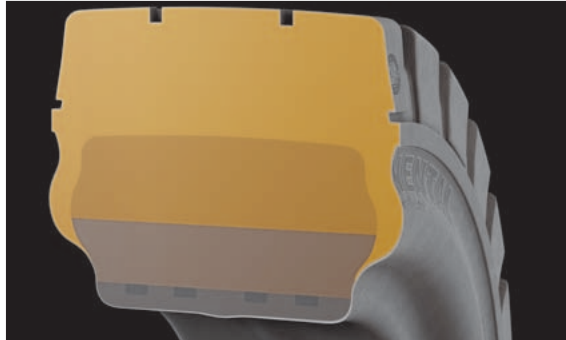

- Enhanced driving comfort thanks to optimum suspension and absorption
 - Optimised aspect ratio



- Lower energy consumption
- Low CO₂ emissions
 - Low rolling resistance



- Very high mileage
 - Greater tread volume



- Extremely quiet running
 - Sturdy central rib/
small tread lug gaps

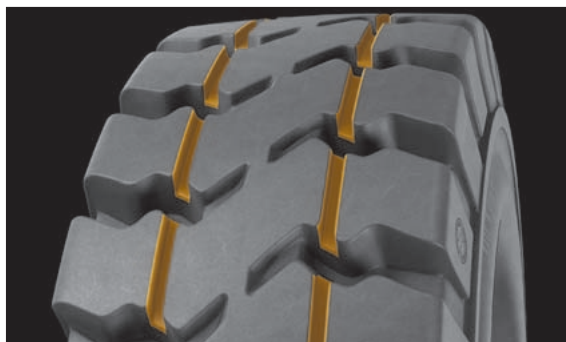

- Outstanding lateral guidance
 - 2 circumferential longitudinal grooves

Core features

Customer benefits

SC 15

Super-Elastic - Solid Tyres

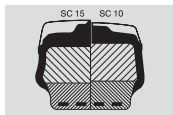

Designed to deliver outstanding life in highly demanding environments, available in SuperClean for non marking on light-coloured surfaces.

- low rolling resistance
- excellent tread depth
- low heat build-up
- low energy consumption on electric vehicles
- long service life for low operating costs

These are improvements that really pay:

The wear volume of the SC 15 has been increased by 30 %, giving it more tread and regrooving depth than the SC 10.

SC 10

Super-Elastic - Solid Tyres



The standard tyre for general demands in universal applications.

- optimal tread design
- low rolling resistance
- compact lugs
- good traction
- low heat build-up
- low energy consumption on electric vehicles
- good ride comfort

SH 12

Super-Elastic - Solid Tyres



Smooth profile tyre for dry and smooth surfaces. Available in SuperClean for non marking on light-coloured surfaces.

- profileless
- solid shoulder
- smooth running for driver comfort
- damage resistant

Core features

Customer benefits

SC 11

Super-Elastic - Solid Tyres



Designed for trailers. Also available in SuperClean for non marking on light-coloured surfaces. The profile is available in size 15x4-8 (125/75-8) and 140/55-9.

- circumferential tread pattern ➡ good stability for safer operation
- flat solid tread ➡ good steering characteristics and greater stability

MIL

Super-Elastic - Solid Tyres



Designed for small tractors and trailers. This tread pattern is available in size 3.00-4.

Continental Super Clean

Ideally suited for the following branches of industry

- foodstuffs
- electronics
- beverages
- paper
- optics
- paint
- pharmaceuticals
- aerospace etc.

The tread and sidewall are made of a wear-resistant, light-coloured rubber compound with high resistance to tear propagation. The CDC Super Clear tyre combines all the outstanding features of the CSE ROBUST SC 15, in addition to offering the following:

- excellent mileage performance
- no contact discoloration
- no black tyre tracks or skid marks

Please note in using CSC tyres:

'Clean' tyres are electrically non-conductive.

Size range, specifications and

Tyre				Rim	Tyre dimensions (in mm)			
Size	Tread pattern	Baseversion			Standard value ¹⁾ pneumatic tyres max. in service		Istwert CSE-Reifen	
		SIT	S		width	outer dia.	width ± 2,0 %	outer dia. ± 1,0 %
acc. to ETRTO ⁶⁾								
3.00-4	MiL		■ ▲ ²⁾	2.10-4	87	260	82	250
4.00-4	SC 10		■ ▲ ²⁾	2.50 C-4	116	318	90	301
140/55-6	SC 15		■ ²⁾	4.50 E-6	130	310	142	310
4.00-8	SC 10	■	■ ²⁾	3.00 D-8	121	422	101	400
	SC 15	■ ▲	■ ²⁾ ▲		121	422	106	402
5.00-8	SC 10	■	■ ²⁾	3.00 D-8	143	476	118	451
	SC 15	■ ▲	■ ▲		143	476	126	459
125/75-8 (15 x 4½-8)	SC 10	■	■ ²⁾	3.00 D-8	132	393	105	371
	SC 11	■ ▲	■ ²⁾		132	393	110	376
	SC 15	■ ▲	■ ▲ ²⁾		132	393	121	377
	SC 20	■	■		132	393	121	377
	SH 12	■ ▲			132	393	121	377
150/75-8 (16 x 6-8)	SC 10	■	■	4.33 R-8	164	434	140	411
	SC 15	■ ▲	■ ▲		164	434	156	417
	SC 20	■	■		164	434	156	417
	SH 12	■ ▲			164	434	156	417
180/70-8 (18 x 7-8)	SC 10	■	■	4.33 R-8	187	471	152	447
	SH 12	■ ▲			187	471	156	454
	SC 15	■ ▲	■ ▲		187	471	156	454
	SC 20	■	■		187	471	156	454
140/55-9	SC 15	■ ▲		4.00 E-9	–	–	131	377
	SC 11	■ ▲			–	–	131	377
	SC 20	■	■		–	–	131	377
6.00-9	SC 10	■	■ ²⁾	4.00 E-9	173	551	138	521
	SC 11		■		173	551	138	521
	SC 15	■ ▲	■ ▲ ²⁾		173	551	143	529
200/75-9 (21 x 8-9)	SC 10	■	■	6.00 E-9	216	546	186	517
	SC 15	■ ▲	■ ▲		216	546	181	524
	SC 20	■	■		216	546	181	524
6.50-10	SC 10	■ ²⁾	■ ²⁾	5.00 F-10	191	600	161	567
	SC 15	■ ▲	■ ▲ ²⁾		191	600	162	576
	SC 20				191	600	162	576
180/60-10	SC 15	■ ▲		5.00 F-10	–	460	160	454

■ CSE-ROBUST ▲ CSC-CLEAN

- 1) To ensure the interchangeability of pneumatic and CSE tyres, the maximum dimensions of a pneumatic tyre are to be taken into account in designing the vehicle's clearance space.
- 2) These rim base types are suitable for centre-split rims.
- 3) Load capacities on vehicles that continuously operate on routes longer than 2000 m available on request.
- 4) Other vehicles: e.g. trailers, self-propelled machines, tractors, mobile cranes, straddle carriers, forklifts without counterweight, side-loading forklifts etc.

tyre load capacities

Rolling circumference (mm) ⁸⁾ ± 2,5 %	Tyre load capacity (kg) ³⁾						Size
	Stationary	on other vehicles ⁴⁾ at max. speed (mph)			on fork lifts max. 16 mph		
		4	6	16	Load wheel ⁷⁾	Steered wheel ⁵⁾	
acc. to ETRTO ⁶⁾							
790	295	260	235	195	260	195	3.00-4
960	620	535	485	412	535	412	4.00-4
1010	1240	1070	970	825	1070	825	140/55-6
1255	1100	950	860	730	950	730	4.00-8
1270	1100	950	860	730	950	730	
1425	1645	1415	1285	1090	1415	1090	5.00-8
1445	1645	1415	1285	1090	1415	1090	
1189	1210	1040	945	800	1040	800	125/75-8 (15 x 4½-8)
1205	1210	1040	945	800	1040	800	
1208	1210	1040	945	800	1040	800	
1208	1210	1040	945	800	1040	800	
1200	1210	1040	945	800	1040	800	
1317	1740	1495	1360	1150	1495	1150	150/75-8 (16 x 6-8)
1336	1740	1495	1360	1150	1495	1150	
1336	1740	1495	1360	1150	1495	1150	
1325	1740	1495	1360	1150	1495	1150	
1435	2490	2145	1945	1650	2145	1650	180/70-8 (18 x 7-8)
1455	2490	2145	1945	1650	2145	1650	
1465	2490	2145	1945	1650	2145	1650	
1465	2490	2145	1945	1650	2140	1650	
1218	1360	1170	1060	900	1170	900	140/55-9
1218	1360	1170	1060	900	1170	900	
1218	1360	1170	1060	900	1170	900	
1650	2190	1885	1710	1450	1885	1450	6.00-9
1650	2190	1885	1710	1450	1885	1450	
1670	2190	1885	1710	1450	1885	1450	
1653	3200	2755	2505	2120	2755	2120	200/75-9 (21 x 8-9)
1680	3200	2755	2505	2120	2755	2120	
1680	3200	2755	2505	2120	2755	2120	
1800	2720	2340	2125	1800	2340	1800	6.50-10
1920	2720	2340	2125	1800	2340	1800	
1920	2720	2340	2125	1800	2340	1800	
1467	2795	2410	2180	1850	2410	1850	180/60-10

5) The steering wheel load capacities for 16 mph (25 km/h) are to be applied for tyres on side-loading forklift truck, straddle carriers and portal lift trucks with a maximum speed of 16 mph (25 km/h).

6) according to DIN 7852.

7) The load ratings are based on an average speed of approx. 6 mph in normal service. Slightly higher top speeds may be reached for a short time.

8) At nominal load (steered wheel 16 mph = 25 km/h).

The minimum dual spacing is indicated on page 84.

 Antistatic Electrostatically effective with an electrical resistance of less than 10⁶ Ohms.
Electric contact between tyre and rim must be ensured.

Note: Prolonged contact with media that cause swelling (such as oil or solvents) reduces the conductivity.

Size range, specifications and

Size	Tyre			Rim	Tyre dimensions (in mm)			
	Tread pattern	Base version			Standard value ¹⁾ pneumatic tyres max. in service		Actual value CSE-Tyres	
		SIT	S		width	outer dia.	width ± 2,0 %	outer dia. ± 1,0 %
acc. to ETRTO 6)								
225/75-10 (23 x 9-10)	SC 10	■	■	6.50 F-10	243	607	195	574
	SH 12	■ ▲			243	607	195	577
	SC 15	■ ▲	■ ▲		243	607	193	583
	SC 20	■	■		243	607	143	583
200/50-10	SC 10	■	■	6.50 F-10	221	467	195	450
	SC 15	■	■		221	467	196	452
	SC 20	■	■		221	467	196	452
	SH 12	■ ▲			221	467	195	450
7.00-12	SC 10	■	■ ²⁾	5.00 S-12	207	685	175	648
	SC 15	■ ▲	■ ▲		207	685	173	657
	SC 20	■	■		207	685	173	657
23x10-12 250/60-12	SC 10	■ ▲	■ ▲	8.00 G-12	275	583	240	574
	SC 20	■	■	8.0 G-12	275	583	234	574
250/75-12 (27 x 10-12)	SC 10	■	■	8.00 G-12	275	704	240	668
	SC 15	■ ▲	■		275	704	233	676
	SC 20	■	■		275	704	233	676
315/45-12	SC 20	■ ▲	■ ▲	10.00 G-12		576	285	574
22 x 4½	SC 10	■		3.1 F-13	143	613	115	574
23 x 5	SC 10	■ ▲	■ ▲	3.75 P-13	167	654	139	613
25 x 6	SC 10	■	■	3.75 P-13	184	700	139	657
7.00-15	SC 10	■	■	5.5-15	213	761	179	717
	SC 15	■	■ ▲		213	761	179	717
7.50-15	SC 10	■	■	6.5-15	234	787	208	746
	SC 15		■	5.5-15	224	787	208	746
	SC 15	■	■	6.5-15	234	787	208	746
8.25-15	SC 10	■	■	6.5-15	253	853	208	807
	SC 10		■	5.5-15	243	853	208	807
	SH 12	■		6.5-15	253	853	206	809
	SC 15	■ ▲	■ ▲		253	853	206	819
	SC 20	■	■		253	853	206	819

■ CSE-ROBUST ▲ CSC-CLEAN

- 1) To ensure the interchangeability of pneumatic and CSE tyres, the maximum dimensions of a pneumatic tyre are to be taken into account in designing the vehicle's clearance space.
- 2) These rim base types are suitable for centre-split rims.
- 3) Load capacities on vehicles that continuously operate on routes longer than 2000 m available on request.
- 4) Other vehicles: e.g. trailers, self-propelled machines, tractors, mobile cranes, straddle carriers, forklifts without counterweight, side-loading forklifts etc.

tyre load capacities

Rolling circumference (mm) ⁸⁾ ± 2,5 %	Stationary	Tyre load capacity (kg) ³⁾					Size
		on other vehicles ⁴⁾			on fork lifts		
		at max. speed (mph)			max. 16 mph		
		4	6	16	Load wheel ⁷⁾	Steered wheel ⁵⁾	
acc. to ETRTO ⁶⁾							
1839	4000	3445	3125	2650	3445	2650	225/75-10 (23 x 9-10)
1854	4000	3445	3125	2650	3445	2650	
1868	4000	3445	3125	2650	3445	2650	
1868	4000	3445	3125	2650	3445	2650	
1450	2870	2470	2240	1900	2470	1900	200/50-10
1473	2870	2470	2240	1900	2470	1900	
1473	2870	2470	2240	1400	2470	1900	
1445	2870	2470	2240	1900	2470	1900	
2065	3380	2920	2645	2240	2920	2240	7.00-12
2105	3380	2920	2645	2240	2920	2240	
2105	3380	2920	2645	2240	2920	2240	
1870	4380	3770	3420	2900	3770	2900	23x10-12
1870	4380	3770	3420	2900	3770	2900	250/60-12
2134	4530	3900	3540	3000	3900	3000	250/75-12 (27 x 10-12)
2166	4530	3900	3540	3000	3900	3000	
2166	4530	3900	3540	3000	3900	3000	
1870	5210	4485	4070	3450	4485	3450	315/45-12
1839	1245	1075	975	825	1075	825	22 x 4½
1964	1735	1495	1355	1150	1495	1150	23 x 5
2102	2565	2210	2005	1700	2210	1700	25 x 6
2307	4115	3545	3215	2725	3545	2725	7.00-15
2307	4115	3545	3215	2725	3545	2725	
2391	4530	3900	3540	3000	3900	3000	7.50-15
2391	4530	3900	3540	3000	3900	3000	
2391	4530	3900	3540	3000	3900	3000	
2570	5510	4750	4300	3650	4750	3650	8.25-15
2570	5510	4750	4300	3650	4750	3650	
2565	5510	4750	4300	3650	4750	3650	
2609	5510	4750	4300	3650	4750	3650	
2609	5510	4750	4300	3650	4750	3650	

5) The steering wheel load capacities for 16 mph (25 km/h) are to be applied for tyres on side-loading forklift truck, straddle carriers and portal lift trucks with a maximum speed of 16 mph (25 km/h).

6) according to DIN 7852.

7) The load ratings are based on an average speed of approx. 10 km/h in normal service. Slightly higher top speeds may be reached for a short time.

8) At nominal load (steered wheel 16 mph = 25 km/h).

The minimum dual spacing is indicated on page 84.



On request, CSE Robust tires of an electrically conductive type are also available.

Size range, specifications and

Tyre		Rim		Tyre dimensions (in mm)				
Size	Tread pattern	Base version		Standard value ¹⁾ pneumatic tyres max. in service		Actual valve CSE tyres		
		SIT	S	width	outer dia.	width ± 2,0 %	outer dia. ± 1,0 %	
acc. to ETRTO ⁶⁾								
225/75-15 (28 x 9-15/ 8.15-15)	SC 10	■	■	7.0-15	233	721	222	683
	SC 15	■ ▲	■ ▲		233	721	221	693
	SC 20	■	■		233	721	216	693
355/45-15 (28 x 12.5-15)	SC 15	■ ▲	■	9.75-15	–	687	291	683
200-15	SC 10	■	■	6.5-15	221	745	208	704
250/70-15 (250-15)	SC 10	■	■	7.0-15	265	750	222	709
	SH 12	■	■		265	750	221	720
	SC 15	■ ▲	■ ▲		265	750	221	720
	SC 20	■	■		265	750	221	720
	SC 15	■	■ ▲	7.5-15	270	750	221	720
315/70-15 (300-15)	SC 10	■	■	8.0-15	324	857	255	811
	SC 15	■ ▲	■ ▲		324	857	252	823
	SC 20	■	■		324	857	252	823
	SH 12	■ ▲			324	857	255	811
355/65-15	SC 10	■	■	9.75-15	372	861	300	811
	SC 15	■ ▲	■ ▲	372	861	291	823	
	SC 20	■	■	9.75-15	372	861	291	823
355/50-20	SH 12	■ ▲		10.0-20	372	861	315	823
8.25-20	SC 15	■	■	6.5-20	253	1002	210	937
10.00-20	SC 15		■	7.5-20	297	1088	265	1025
				6.5-20	287	1088	265	1025
			■	8.0-20	302	1088	265	1025
12.00-20	SC 15		■	8.5-20	337	1163	270	1089
			■	8.0-20	332	1163	270	1089
			■ ▲	10.0-20	352	1163	308	1089
12.00-24	SC 15		■	8.5-24	337	1263	280	1185
			■	10.0-24	305	1263	305	1185
14.00-24	SC 15		■ ▲	10.0-24	405	1391	325	1287

■ CSE-ROBUST ▲ CSC-CLEAN

- 1) To ensure the interchangeability of pneumatic and CSE tyres, the maximum dimensions of a pneumatic tyre are to be taken into account in designing the vehicle's clearance space.
- 2) These rim base types are suitable for centre-split rims.
- 3) Load capacities on vehicles that continuously operate on routes longer than 2000 m available on request.
- 4) Other vehicles: e.g. trailers, self-propelled machines, tractors, mobile cranes, straddle carriers, forklifts without counterweight, side-loading forklifts etc.

tyre load capacities

Rolling circumference (mm) ⁸⁾ ± 2,5 %	Tyre load capacity (kg) ³⁾						Size
	Stationary	on other vehicles ⁴⁾			on fork lifts		
		at max. speed (mph)			max. 16 mph		
		4	6	16	Load wheel ⁷⁾	Steered wheel ⁵⁾	
acc. to ETRTO ⁶⁾							
2189	4380	3900	3540	3000	3900	3000	225/75-15
2240	4380	3900	3540	3000	3900	3000	(28 x 9-15/ 8.15-15)
2247	6420	5525	5015	4250	5525	4250	355/45-15 (28 x 12.5-15)
2256	3670	3160	2865	2430	3180	2430	200-15
2296	5510	4750	4300	3650	4750	3650	250/70-15 (250-15)
2305	5510	4750	4300	3650	4750	3650	
2307	5510	4750	4300	3650	4750	3650	
2307	5510	4750	4300	3650	4750	3650	
2599	6795	5850	5310	4500	5850	4500	315/70-15 (300-15)
2645	6795	5850	5310	4500	5850	4500	
2645	6745	5850	5310	4500	5850	4500	
2599	6795	5850	5310	4500	5850	4500	355/65-15
2632	9060	7000	6430	5450	7800	6000	
2675	9060	7000	6430	5450	7800	6000	
2675	9060	2000	6430	5450	7800	6000	355/50-20
2720	10440	8990	8160	6915	8990	6915	
2992	5550	4400	4335	3675	4400	3675	
3250	7550	6000	5450	5000	6000	5000	10.00-20
3250	7550	6000	5450	5000	6000	5000	
3250	7550	6000	5450	5000	6000	5000	
3486	9440	7500	6810	6250	7500	6250	12.00-20
3486	9440	7500	6810	6250	7500	6250	
3486	9770	7765	7050	6470	7765	6470	
3792	10040	7980	7250	6650	7980	6650	12.00-24
3792	10040	7480	7250	6650	7986	6650	
4135	13855	11000	10000	9175	11000	9175	14.00-24

5) The steering wheel load capacities for 16 mph (25 km/h) are to be applied for tyres on side-loading forklift truck, straddle carriers and portal lift trucks with a maximum speed of 16 mph (25 km/h).

6) according to DIN 7852.

7) The load ratings are based on an average speed of approx. 10 km/h in normal service. Slightly higher top speeds may be reached for a short time.

8) At nominal load (steered wheel 16 mph = 25 km/h).

The minimum dual spacing is indicated on page 84.



On request, CSE Robust tires of an electrically conductive type are also available.

Continental Press-on bands – puncture-proof and maintenance-free



To meet the full span of different requirements we offer a large programme of tyres. In toughest conditions these rubber tyres provide a failsafe and maintenance-free solution. But also with electric forklifts Elastic offers economic performance due to its low rolling resistance.

Elastic steel-based press-on bands

offer the smallest possible sizes for ultra-heavy loads. The press-on band consists of a steel ring with a vulcanised-on rubber cushion. This structure provides for good heat dissipation, via the steel ring, and the best possible adhesion of rubber to steel.

The steel-based tyres attain outstanding mileage performance, even under full utilisation of their speed and load potential.

The sturdy steel ring allows for a symounting and effectively protects the sides an the rim.





Elastict yres with steel wire reinforcement

have several wire cores embeded in a tyre base made of a special tough, hard rubber compound. This design gives the tyre a particularly close fit on the rim through high friction between rubber and steel rim. This proven design permits remarkably high load capacities. The light-coloured Clean version corresponds to the compound used in the CSE tyres, and so reduce the traces of black rubber even under braking.





Please note in using CSC tyres

The tyre is electrically non-conductive. The vehicles must therefore be earthed in another suitable way following consultation with the supervisory authorities.

The Tread Layer Designs

Type	Symbol	Application
L		Press-on tyres with an exceptional free running ability for non- driven and non-braked wheels.
A		For driven and braked wheels which perform under arduous conditions and need to be exceptionally wear resistant and of high structural durability.
A-ROBUST		Well-cushioned, wide elastic tyres are made in this version to lower both the rolling resistance and the heat build-up, with the following distinctive features: • extreme cost-efficiency • excellent rolling resistance • capability of with standing sustained use under maximum load. (For sizes see page 46-49).
ANTISTATIC (CONDUCTIVE)		Electrostatically effective with an electrical resistance of less than 10 ⁶ Ohms. Electric contact between tyre and rim must be ensured. Note: Prolonged contact with media that cause swelling (such as oil or solvents) reduces the conductivity.
CLEAN		A non-marking compound for light-coloured, clean industrial floors.

The rim versions*

			
Tyres with steel base	Tyres with steel wire reinforcement		
cylindrical base (STB)	cylindrical base (Z)	tapered base, centre-split (km 8, km 10, km 15)	tapered base, offset-split (ks 15/6, ks 15/8)

* Elastic-wheels are available on request

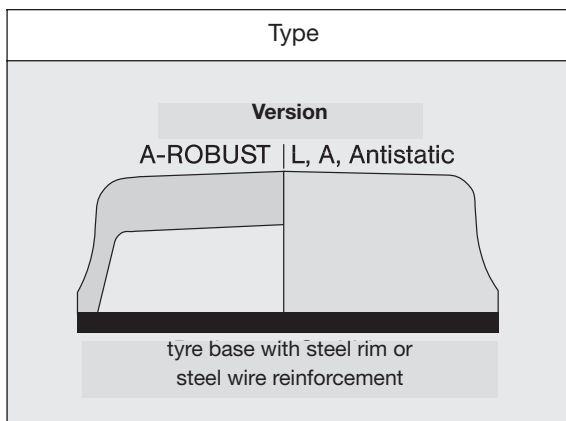

Steel banded press-on bands acc. to DIN 7845 resp. ETRTO

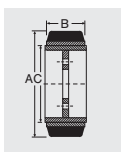

● MH 20



■ MC 20

Tyre Size ¹⁾			Tyre load capacity (kg) at max. speed (mph)							
Inch (A x B x C)	mm (A x B x C)	Pattern	on counterblanced- fork-lift-trucks up to				on other vehickles ²⁾ up to			
			6 mph		10 mph		4 mph	6 mph	10 mph	hand- drawn
			Load wheel	Steered wheel	Load wheel	Steered wheel				
	180/ 50-120	●	-	-	-	-	-	-	185	310
	250/ 75-140	●	-	-	-	-	-	-	400	665
	250/130-140	● 4)	1065	875	950	800	1065	875	800	-
	265/160-160	●	1415	1165	1265	1060	1415	1165	1060	-
10 x 4 x 6½	254/102-165	● 4)	780	640	695	585	780	640	585	-
10 x 5 x 6½	254/127-165	●	1010	830	905	760	1010	830	760	-
10½ x 5 x 6½	267/127-165	●	1075	885	960	805	1075	885	805	-
	230/ 50-170	●	-	-	-	-	-	-	225	370
	230/ 75-170	●	-	-	-	-	-	-	370	615
	250/ 80-170	●	-	-	-	-	-	-	440	735
	250/105-170	● 4)	785	645	700	590	785	645	590	-
	250/ 60-190	●	-	-	-	-	-	-	300	495
	250/ 85-190	■ ●	-	-	-	-	-	-	455	760
	280/ 60-190	●	-	-	-	-	-	-	325	540
	300/100-203	●	870	715	755	620	870	715	620	-
13 x 3½ x 8	330/ 89-203	●	785	645	705	590	785	645	590	-
13 x 4½ x 8	330/114-203	●	1120	920	1000	840	1120	920	840	-
13 x 5 x 8	330/127-203	■	1290	1060	1150	965	1290	1060	965	-
13½ x 5½ x 8	343/140-203	■ ● 4)	1505	1235	1345	1130	1505	1235	1130	-
14 x 4½ x 8	356/114-203	■ ● 4)	1170	960	1045	875	1170	960	875	-
	280/ 50-220	●	-	-	-	-	-	-	260	430
	285/ 75-220	●	-	-	-	-	-	-	425	710
16 x 5 x 10½	406/127-267	■ 4) 5)	1510	1240	1345	1130	1510	1240	1130	-
16 x 6 x 10½	406/152-267	■ 4) 5)	1915	1570	1710	1435	1915	1570	1435	-
	360/ 60-270	●	-	-	-	-	-	-	390	655
	360/ 85-270	●	-	-	-	-	-	-	635	-
15 x 5 x 11¼	381/127-286	■ ●	1390	1145	1240	1045	1390	1145	1045	-
15 x 6 x 11¼	381/152-286	■	1715	1410	1535	1290	1715	1410	1290	-
16¼ x 5 x 11¼	413/127-286	■ ●	1525	1250	1360	1145	1525	1250	1145	-
16¼ x 6 x 11¼	413/152-286	■ ●	1920	1575	1715	1440	1920	1575	1440	-
16¼ x 7 x 11¼	413/178-286	■ ● 5)	2315	1900	2065	1735	2315	1900	1735	-

1) Tolerances: OD ± 1,5%, width ± 4%.

2) This includes drive and steered -axle wheels of other lift trucks, mobile cranes, free-rolling wheels on other vehicles (trailers) for distances of up to 2000 m per journey. Please consult manufacturer with respect to longer distances and with regard to use as jockey wheels on drum drives.

3) Type: A-ROBUST (explanation see page 43).

4) MH 20 also available in the Clean version.

5) MC 20 also available in the Clean version.

● MH20 ■ MC20

Tyre size ¹⁾			Tyre load capacity (kg) at max. speed (mph)							
Inch (A x B x C)	mm (A x B x C)	Pattern	on counterbalanced- fork-lift-trucks up to				on other vehicles ²⁾ up to			
			6 mph		10 mph		4 mph	6 mph	10 mph	hand- drawn
			Load wheel	Steered wheel	Load wheel	Steered wheel				
	405/ 65-305	●	-	-	-	-	-	-	475	790
	405/130-305	●	1510	1240	1345	1130	1510	1240	1130	-
	405/260-305	●	3325	2730	2970	2495	3325	2730	2495	-
	415/ 75-305	●	-	-	-	-	-	-	585	975
	415/ 90-305	●	-	-	-	-	-	-	760	-
	415/100-305	●	1115	915	995	835	1115	915	835	-
	415/200-305	●	2610	2140	2330	1960	2610	2140	1960	-
	425/150-305	●	1910	1570	1705	1430	1910	1570	1430	-
	425/260-305	●	3615	2970	3230	2710	3615	2970	2710	-
	425/300-305	●	4245	3490	3790	3185	4245	3490	3185	-
	450/260-305	●	3945	3240	3520	2960	3945	3240	2960	-
	450/300-305	●	4650	3820	4150	3490	4650	3820	3490	-
17 x 4½ x 12½	432/114-308	●	1370	1125	1225	1030	1370	1125	1030	-
18 x 5 x 12½	457/127-308	■ ● 4) 5)	1645	1350	1465	1230	1645	1350	1230	-
18 x 6 x 12½	457/152-308	■ ● 4) 5)	2095	1720	1870	1575	2095	1720	1575	-
18 x 7 x 12½	457/178-308	■ ● 4) 5)	2550	2095	2280	1915	2550	2095	1915	-
18 x 8 x 12½	457/203-308	■ ● 4) 5)	3005	2470	2685	2255	3005	2470	2255	-
18 x 9 x 12½	457/229-308		3460	2840	3090	2595	3460	2840	2595	-
	520/100-370	●	1275	1045	1140	955	1275	1045	955	-
21 x 5 x 15	533/127-381	●	1840	1510	1645	1380	1840	1510	1380	-
21 x 6 x 15	533/152-381		2355	1935	2105	1765	2355	1935	1765	-
21 x 7 x 15	533/178-381	■ ● 4) 5)	2870	2355	2560	2150	2870	2355	2150	-
21 x 8 x 15	533/203-381	■ ● 4) 5)	3385	2780	3020	2535	3385	2780	2535	-
21 x 9 x 15	533/229-381	● 4)	3895	3200	3480	2925	3895	3200	2925	-
22 x 6 x 16	559/152-406	● 4)	2440	2005	2180	1830	2440	2005	1830	-
22 x 8 x 16	559/203-406	■ ● 3) 4) 5)	3505	2880	3130	2625	3505	2880	2625	-
22 x 9 x 16	559/229-406	■ ● 3) 4) 5)	4035	3315	3605	3025	4035	3315	3025	-
22 x 10 x 16	559/254-406	■ ● 3) 4) 5)	4570	3750	4080	3425	4570	3750	3425	-
22 x 12 x 16	559/305-406	■ ● 3) 4) 5)	5630	4625	5030	4225	5630	4625	4225	-
22 x 14 x 16	559/356-406	● 3)	6415	5510	5995	5035	6415	5510	5035	-
22 x 16 x 16	559/406-406	● 3)	7765	6380	6930	5820	7765	6380	5820	-
	500/ 65-410	●	-	-	-	-	-	-	565	940
	560/100-410	●	1350	1105	1205	1010	1350	1105	1010	-
	550/160-410	●	2550	2095	2280	1915	2550	2095	1915	-
	610/150-410	●	2500	2055	2235	1875	2500	2055	1875	-
	620/200-410	● 3)	3785	3105	3380	2835	3785	3105	2835	-
	645/250-410	● 3)	4805	3930	4180	3430	4805	3930	3430	-
	645/300-410	● 3) 4)	6055	4955	5270	4325	6055	4955	4325	-
	645/200-480	● 3) 4)	3860	3170	3445	2895	3860	3170	2895	-
	645/250-480	● 3)	4635	3795	4035	3310	4635	3795	3310	-
	670/200-480	● 3)	4010	3295	3580	3005	4010	3295	3005	-
	760/250-500	● 3)	5440	4450	4735	3885	5440	4450	3885	-
28 x 10 x 22	711/254-559	● 3)	5460	4490	4880	4100	5460	4490	4100	-
28 x 12 x 22	711/305-559	■ ● 3) 4)	6740	5540	6020	5050	6740	5540	5050	-
28 x 14 x 22	711/356-559	●	8020	6580	7160	6010	8020	6580	6010	-
28 x 16 x 22	711/406-559	● 3)	9280	7620	8290	6960	9280	7620	6960	-
	840/356-559	● 3) 4)	9100	7445	7920	6500	9100	7445	6500	-
	920/250-670	● 3)	6280	5140	5460	4490	6280	5140	4490	-

Press-on bands with steel wire reinforcement

acc. to DIN 7845 resp. ETRTO

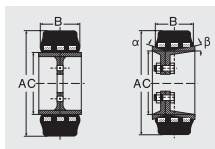

● MH 20



■ MC 20

Tyre size ¹⁾		Tyre version ²⁾		Tyre load capacity (kg) at max. speed (mph)							
Inch (A x B x C)	mm (A/B-C)	cylindr. z	tapered k (km α) (km α/β)	on other vehicles up to				on fork lifts			
				4	6	10	12	up to 6 mph		up to 10 mph	
				Load wheel	Steered wheel	Load wheel	Steered wheel	Load wheel	Steered wheel	Load wheel	Steered wheel
	105/ 45- 65	●		120	100	-	-	-	-	-	-
	125/ 50- 75	●	● km 15	160	130	-	-	-	-	-	-
	150/ 50-100	●	● km 15	225	180	-	-	-	-	-	-
	160/ 50-100	●	● km 15	250	200	-	-	-	-	-	-
	170/ 75-100	● ■		425	340	260	210	-	-	-	-
	180/ 75-100		● km 15	425	340	260	210	-	-	-	-
	200/ 75-100		● km 15	500	400	300	250	-	-	-	-
	200/ 85-105	●	●	550	440	330	280	-	-	-	-
	180/100-105		● km 8	625	550	380	310	570	470	510	430
	180/ 50-120	●	● km 15	325	260	-	-	-	-	-	-
	230/ 75-120	●		550	440	330	280	-	-	-	-
	200/ 50-140	●	●	350	280	-	-	-	-	-	-
	250/ 75-140	●	●	625	500	380	310	-	-	-	-
	250/100-140	●		750	600	450	375	765	625	680	575
	200/ 60-150	●		425	340	260	210	-	-	-	-
	265/160-160	●		1150	920	690	580	1420	1165	1265	1065
	230/ 50-170	●	● km 15	400	320	240	200	-	-	-	-
	250/ 60-170	●	● km 15	550	440	330	280	-	-	-	-
	260/ 60-170	●	● km 15	525	420	320	260	-	-	-	-
	250/ 75-170		● km 15	650	520	390	330	-	-	-	-
	280/ 75-170		● km 15	700	560	420	350	-	-	-	-
	250/ 80-170	● ▲		675	540	410	340	-	-	-	-
	300/ 85-170	●		800	640	480	400	-	-	-	-
	310/100-170	●		950	760	580	480	880	725	785	660
	270/105-170		● km 8	900	720	540	450	855	705	765	645
	250/ 50-190	●		450	360	270	230	-	-	-	-
	250/ 60-190	●		525	420	320	260	-	-	-	-
	280/ 60-190	●		575	460	350	290	-	-	-	-

Please consult manufacturer with respect to longer distances and with regard to use as jockey wheels on drum drives.

1) Tolerances: OD $\pm 1,5\%$, width $\pm 4\%$.

2) Explanation: ● MH 20 ■ MC 20 ▲ also available in the Clean version.

3) Tyres for use on public roads (60-joule tyres). Special load capacities on request.

4) Type: A-ROBUST (See page 43 for explanation).

Further sizes on request.

Tyre size 1)		Type version 2)		Tyre load capacity (kg) at max. speed (mph)							
Inch (A x B x C)	mm (A/B-C)	cylindr. z	tapered k (km a) (km a/b)	on other vehicles up to mph				on fork lifts			
				4	6	10	12	Load wheel	Steered wheel	Load wheel	Steered wheel
	310/ 75-200		● km 15	750	600	450	380	-	-	-	-
	285/100-200		● km 8	925	740	560	460	825	675	735	620
	310/120-200		ks15/6 ●	1050	840	630	530	1135	930	1010	850
	310/140-200		ks15/6 ●	1225	975	725	600	1370	1125	1225	1030
	300/ 90-203	●		900	720	540	450	-	-	-	-
	300/100-203	●	● km 8	975	780	590	490	870	715	775	650
	313/130-203		● km 8	1150	920	690	580	1260	1035	1125	945
13½ x 5½ x 8	343/140-203		ks15/6 ●	1350	1075	810	680	1510	1240	1345	1130
	280/ 50-220	●		525	420	320	260	-	-	-	-
	300/ 50-220		● km 15	550	440	330	280	-	-	-	-
	310/ 60-220	●		650	520	390	330	-	-	-	-
	280/ 75-220		● km 10	725	580	440	360	-	-	-	-
	300/ 75-220	●	● km 10	750	600	450	380	-	-	-	-
	310/120-220	●		1050	840	630	530	1105	905	985	830
	405/160-250		ks15/6 ●	1550	1240	930	780	2045	1680	1825	1530
16 x 5 x 10½	406/127-267		ks15/6 ●	1350	1075	810	680	1510	1240	1345	1130
16 x 6 x 10½	406/152-267		ks15/6 ●	1575	1250	950	790	1910	1570	1710	1435
16 x 7 x 10½	406/178-267		ks15/6 ●▲	1800	1450	1075	900	2325	1910	2070	1740
	360/ 60-270	●	● km 15	750	600	450	380	-	-	-	-
	360/ 75-270	●	● km 15	950	760	570	480	-	-	-	-
	360/ 85-270	●	● km 15	1050	840	630	530	-	-	-	-
	400/ 65-305	●		900	720	540	450	-	-	-	-
	400/ 75-305	●	● km 15	1000	800	600	500	-	-	-	-
	415/ 90-305	●	● km 15	1150	920	690	580	-	-	-	-
	415/100-305	●	● km 8	1250	1000	750	630	1115	915	1000	835
	455/100-305	●		1400	1120	840	700	1155	950	1030	865
	405/130-305	●		1500	1200	900	750	1510	1240	1350	1135
	425/150-305		ks15/6 ●	1800	1450	1100	900	1910	1570	1700	1435
18 x 7 x 12½	457/178-308		ks15/6 ●	2000	1600	1200	1000	2550	2100	2280	1910
21 x 9 x 13	533/229-330		ks15/8 ●▲	3000	2400	1800	1500	3690	3020	3210	2635
	500/ 85-370	●		1300	1050	780	650	-	-	-	-
	520/100-370	●		1525	1225	920	760	1275	1050	1140	955
	525/120-370	●		1800	1450	1075	900	1675	1375	1500	1260
	500/125-370	●		1800	1450	1075	900	-	-	-	-
21 x 9 x 15	533/229-381		ks15/8 ●▲	3000	2400	1800	1500	3900	3200	3475	2920
	500/ 65-410	●		1100	880	660	550	-	-	-	-
	560/100-410 ³⁾	●		1600	1275	960	800	1350	1110	1205	1015
	550/120-410	●	● km 8	1825	1450	1100	910	1750	1440	1565	1315
	590/120-410 ³⁾	●		1900	1525	1150	950	1780	1460	1590	1335
	610/150-410 ³⁾	●		2250	1800	1350	1125	2505	2055	2235	1880
	550/160-410	●		2250	1800	1350	1125	2550	2100	2280	1915
	540/200-410	●		3000	2400	1800	1500	3790	3110	3290	2705
	620/200-410 ^{3,4)}	●		3000	2400	1800	1500	3790	3110	3380	2840
	645/250-410 ^{3,4)}	●		3750	3000	2250	1875	4810	3930	4180	3430
	645/300-410 ⁴⁾	●		4700	3750	2800	2350	6060	4960	5275	4330
	645/200-480 ⁴⁾	●	ks15/8 ●▲	3100	2475	1850	1550	3865	3175	3450	2900
	750/ 75-640	●		1750	1400	1050	875	-	-	-	-

MPT Tyres

General Characteristics

MPT Tyres are designed for mixed on-/off-road use and with a strong emphasis on winter operations. The construction and tread design enables the tyres to give excellent traction and also to be able to run to a high speed index.

Special applications by construction

Radial:

- enhanced mileage
- very comfortable
- higher speed rating
- increased traction

Crossply:

- resistant to sidewall damage
- good traction
- effective damping

Suitable vehicles

- multi-purpose vehicles
- off-road lift trucks
- wheel loaders
- graders
- agricultural vehicles
- telescopic lifts
- digger loaders

General applications

- construction sites
- military
- agriculture
- explorations
- municipal yards
- health care
- expeditions

Core features

Customer benefits

MPT 81

Radial – MPT



Highly suitable for use on utility vehicles working on surfaced and unsurfaced roads.

Winter maintenance/Council services

- large tread lug footprint ➡ more traction and high mileage
- high traction tread pattern ➡ ensures mobility on soft ground
Laufflächenprofil
- quiet

Core features

Customer benefits

MPT 80

Radial – MPT



Highly suitable for use on utility vehicles working on surfaced and unsurfaced roads.

- large tread lug footprint
 - high traction tread pattern
- ➡ more traction and high mileage
 - ➡ ensures mobility on soft ground

MPT MIL

Radial – MPT



The MPT-Tyre with a non-directional profile and good on-road characteristics. This profile is available in size 12.5R20.

- radial construction
 - wide tread pattern and rounded ground profile
 - optimal tread design
- ➡ high driver comfort
 - ➡ self-cleaning
 - ➡ good traction

MPT 70 E

Radial – MPT



The MPT-Tyre for heavy usage on small construction vehicles, both off-road and on-site.

- robust tread pattern
 - wear-resistant tread compound
 - open tread
- ➡ ideal for use on stony ground
 - ➡ very high mileage
 - ➡ good traction and self-cleaning

MPT crossply tyres – universal for all applications

	Core features	Customer benefits
	MPT E 6	Cross-ply – MPT
	<p>Ideal for on and off-road. Also adapted for snow clearance.</p> <ul style="list-style-type: none"> • robust cross-ply carcass • optimised tread pattern 	<ul style="list-style-type: none"> ⇒ excellent steering control on snowplough ⇒ applications resistant to tyre wall damage ⇒ high cornering power and good traction
	MPT 30	Cross-ply – MPT
	<p>The traction profile for unpaved surfaces.</p> <ul style="list-style-type: none"> • strong, wear-resistant lugs • open directional tread pattern 	<ul style="list-style-type: none"> ⇒ good mileage ⇒ good traction ⇒ good mobility on challenging terrain

Core features

Customer benefits

MPT Titan

Cross-ply – MPT



The MPT Titan is particularly suited for road application. Available in size 10.5-20.

- high percentage of tread in contact with the road
- robust cross-ply carcass
- ⇒ low noise levels for driver comfort, high mileage
- ⇒ resistant to tyre wall damage

MPT E5

Cross-ply – MPT



The MPT-Cross-ply-Tyre for off-road use. Available in size 10.5-18.

- open tread pattern
- robust cross-ply carcass
- ⇒ excellent off-road traction and cornering
- ⇒ resistant to tyre wall damage

MPT MIL

Cross-ply – MPT



The MPT-Tyre with non-directional profile and good on-road characteristics. The profile is available in size 10.5-20.

- cross-ply construction
- optimal tread design
- wide tread pattern and rounded ground profile
- ⇒ increased lateral stability
- ⇒ good traction
- ⇒ very good traction and self cleaning

Operating instructions (DIN 7793 and ECE-R54)

MPT = Multi Purpose Tyres

Load capacity and speed.

When determining the minimum tyre size necessary for a vehicle, the approved axle load and the maximum design speed of the vehicle should always be used as a basis. The so-called “list of tolerances” must also be considered.

Nominal load capacity = 100% load, as indicated by the Load Index (LI)*

Reference speed.

The reference speed is classified according to the nominal load capacity of the tyre.

Tyre pressure.

The tyre pressures given in the tables are minimum tyre pressures and should be regarded as a guide only. For special operating conditions specific tyre pressure may be recommended. All tyre pressures refer to the “cold” tyre which has been standing outdoors for several hours, not exposed to intense sunlight.

Mixed tyres.

Although on vehicles over 2.8 t in weight different tyre designs are permitted per axle, we recommend fitting the same design on all wheel positions.

Rims.

Only the rims detailed in this book may be fitted for use on the tyres shown.

Wheels.

The load capacity of the wheels used must always be adequate.

According to ECE-Regulation No. 54 MPT tyres for speeds of 50 mph (80km/h) and over must carry an operating code, consisting of the Load Index (LI)* and the Speed Index (SI).

*see table page 9.

Load capacities for various maximum design speeds and for special applications

Maximum speed in km/h (determined by vehicle design)	Approved load capacity in % of the nominal load capacity according to Load Index for reference speed			
	E (70 km/h)	G (90 km/h)	J (100 km/h)	K (110 km/h)
120	–	–	88	93
115	–	–	93	97
110	–	87	96	100
107,5	–	89,5	97	100
105	–	92	98	100
102,5	–	93,5	99	100
100	–	95	100	100
95	–	97,5	101	101
90	83	100	102	102
85	88	103	103	103
75	96,5	105,5	105,5	105,5
70	100	107	107	107
65	105	108,5	108,5	108,5
60	110	110	110	110
55	111	111	111	111
50	112	112	112	112
45	113	113	113	113
40 ¹⁾	115	115	115	115
35 ¹⁾	119	119	119	119
30 ¹⁾	125	125	125	125
25 ¹⁾	135	135	135	135
20 ¹⁾	150	150	150	150
15 ¹⁾	165	165	165	165
Application-restricted speed				
10 ^{1) 2)}	180	180	180	180
5 ^{1) 2)}	210	210	210	210
Stillstand ^{1) 2)}	250	250	250	250

1) Twin tyre load capacity = 2 x single tyre load capacity. 2) For these applications please contact tyre manufacturer.

Special application	Type of operation	Approved load capacity in %
1	Special vehicles: Fire engines with special super structure, road-washing vehicles, road-sweepers, refuse lorries, mobile working platforms and similar vehicles in municipal services and other public use.	of the above approved load capacity at the respective speed 110
2	Tyres on the front axle of trucks equipped for snow-clearing (front-mounted snow plough, front-mounted snow blower etc.) for application-restricted speeds of 30 mph (50 km/h) 38 mph (62 km/h)	the nominal load capacity 120 115

Technical data and load capacities

Size	Tyre			Rim	TL-Valve	Normal dimensions in service		Continental Tyre dimensions		Static radius	Rolling circumference Tol. ± 2,5 %
	PR	Operational code ¹⁾	Tread			width max.	outer dia. max.	width	outer dia.		
10.5 R 20 TL	10	128 J	MPT 80	9 x 20	43 GS 16 ²⁾	284	968	265	950	444	2865
	14	134 J	MPT 80	9 x 20	43 GS 16 ²⁾	284	968	265	950	444	2865
12.5 R 20 TL	12	132 J	MPT 80, MIL	11 x 20 ³⁾ oder 11-20 SDC	43 GS 16 ²⁾	340	1056	320	1030	480	3120
	16	139 J ³⁾	MPT 80		43 GS 16 ²⁾	340	1056	320	1030	480	3120
	22	147 J ³⁾	MPT 80		43 GS 16 ²⁾	340	1056	320	1030	480	3120
14.5 R 20 TL	10	132 J	MPT 80	11 x 20 ³⁾ oder 11-20 SDC	43 GS 16 ²⁾	373	1113	352	1090	503	3285
	18	143 J ³⁾	MPT 80		43 GS 16 ²⁾	373	1113	352	1090	503	3285
	–	152 J ³⁾	MPT 80		43 GS 16 ²⁾	373	1113	352	1090	503	3285
with size in mm											
315/55 R 16 TL	120 K	MPT 81	MPT 81	10, 10 LB 11	43 GS 11.5	–	–	307	750	348	2262
					43 GS 16	329	762	317	750	348	2262
275/80 R 20 TL (10.5 R 20)	134 K	MPT 81	MPT 81	9, 9 SDC W 9	43 GS 16 ²⁾	289	974	265	950	440	2850
335/80 R 20 TL (12.5 R 20)	147 K	MPT 81	MPT 81	W10 11, 11 SDC W 11	43 GS 16 ²⁾	354	1076	310	1032	480	3120
					43 GS 16 ²⁾	–	–	320	1032	480	3120
365/80 R 20 TL (14.5 R 20)	152 K	MPT 81	MPT 81	11 11 SDC 12 SDC	43 GS 16 ²⁾	378	1116	365	1089	502	3275
					43 GS 16 ²⁾	378	1116	365	1089	502	3275
with MPT 70 E tread for construction site vehicles											
325/70 R 18 TL	125 E	MPT 70 E	MPT 70 E	9 11, 11SDC	43 GS 16 ²⁾	328	940	313	933	423	2863
					43 GS 16 ²⁾	350	940	333	933	423	2863
365/70 R 18 TL	133 E	MPT 70 E	MPT 70 E	11 SDC 12	43 GS 16 ²⁾	400	1000	365	969	428	2895
					43 GS 16 ²⁾	411	1000	375	969	428	2895
335/80 R 20 TL	134 E	MPT 70 E	MPT 70 E	9, 11	43 GS 16 ²⁾	344	1076	298	1041	480	3120
					43 GS 16 ²⁾	366	1076	318	1041	480	3120
365/80 R 20 TL	139 E	MPT 70 E	MPT 70 E	11, 11SDC 12	43 GS 16 ²⁾	378	1116	378	1116	500	3302
					43 GS 16 ²⁾	389	1116	378	1116	500	3302
405/70 R 20 TL	141 E	MPT 70 E	MPT 70 E	12 13, 13SDC	43 GS 16 ²⁾	441	1121	426	1062	486	3227
					43 GS 16 ²⁾	452	1121	426	1062	486	3227
455/70 R 24	152 E	MPT 70 E	MPT 70 E	W 14 L W 15 L	43 GS 16 ²⁾	–	–	435	1223	540	3620
					43 GS 16 ²⁾	–	–	446	1223	540	3620

1) Load index single wheel fitment and speed index

2) Valve 50 MSW optional

3) Over LI 32 please check rim load capacity

PR	Load Index LI	Load capacity (kg) per tyre at tyre pressure Single tyre fitment												Speed index and ref. speed (km/h)	Size
		kPa	250	300	350	375	400	425	450	500	525	600	650		
		bar	2,0	2,5	3,0	3,5	3,75	4,0	4,25	4,5	5,0	5,25	6,0		
10	128	990	1185	1370	1550	1635	1715	1800						J 100	10.5 R 20 TL
14	134	990	1185	1370	1550	1635	1715	1800	1875	2030	2120		J 100		
12	132	1320	1575	1800	2000									J 100	12.5 R 20 TL
16	139	1320	1575	1800	2000	2120	2240	2335	2430				J 100		
22	147	1320	1575	1800	2000	2120	2240	2335	2430	2625	2710	2975	3075	J 100	
10	132	1445	1730	2000										J 100	14.5 R 20 TL
18	143	1445	1730	2000	2290	2430	2575	2650	2725					J 100	
-	152	1445	1730	2000	2290	2430	2575	2650	2725	3000	3125	3550		J 100	
with size in mm															
-	120	895	1070	1240	1400									K (110)	315/55 R 16 TL
-	120	895	1070	1240	1400									K (110)	
-	134	990	1185	1370	1550	1635	1715	1800	1875	2030	2120			K (110)	275/80 R 20 TL (10.5 R 20)
-	147	1320	1575	1800	2000	2120	2240	2335	2430	2625	2710	2975	3075	K (110)	335/80 R 20 TL (12.5 R 20)
-	147	1320	1575	1800	2000	2120	2240	2335	2430	2625	2710	2975	3075	K (110)	335/80 R 20 TL (12.5 R 20)
-	152	1445	1730	2000	2290	2430	2575	2650	2725	3000	3125	3550		K (110)	365/80 R 20 TL (14.5 R 20)
-	152	1445	1730	2000	2290	2430	2575	2650	2725	3000	3125	3550		K (110)	365/80 R 20 TL (14.5 R 20)
with MPT 70 E tread for construction site vehicles															
-	125	1010	1200	1380	1560	1650								E (70)	325/70 R 18 TL
-	125	1010	1200	1380	1560	1650								E (70)	
-	133	1250	1490	1720	1950	2060								E (70)	365/70 R 18 TL
-	133	1250	1490	1720	1950	2060								E (70)	
-	134	1280	1530	1770	2005	2120								E (70)	335/80 R 20 TL
-	134	1280	1530	1770	2005	2120								E (70)	
-	139	1470	1770	2030	2300	2430								E (70)	365/80 R 20 TL
-	139	1470	1770	2030	2300	2430								E (70)	
-	141	1560	1860	2150	2240	2575								E (70)	405/70 R 20 TL
-	141	1560	1860	2150	2240	2575								E (70)	
-	152	1885	2355	2840	3300	3550								E (70)	455/70 R 24
-	152	1885	2355	2840	3300	3550								E (70)	

Recommended tyre pressures for tyres on off-road vehicles

Tyre size	Pattern	Load Index (PR)	Load capacity (kg) per tyre	Tyre pressure			
				on firm ground (plowland, grassland, runways)		on loose ground (sand, mud)	
				V _{max} 50 km/h		V _{max} 50 km/h	
				bar	kPa	bar	kPa
315/55 R 16	MPT 81	120	1400	3,0	300	2,0	200
		120	1060	2,5	250	1,5	150
		120	750	1,5	150	1,0	100
275/80 R 20 19.5 R 20	MPT 81	128 (10 PR)	1500	2,4	240	1,5	150
		128 (10 PR)	1650	2,7	270	1,7	170
		128 (10 PR)	1500	3,0	300	1,9	190
		134 (14 PR)	1950	3,4	340	2,1	210
		134 (14 PR)	2120	3,8	380	2,4	240
335/80 R 20 12.5 R 20	MPT 81 MPT 80	132 (12 PR)	1650	2,0	200	1,1	110
		132 (12 PR)	1800	2,1	210	1,2	120
		132 (12 PR)	1950	2,4	240	1,4	140
		139 (16 PR)	2120	2,7	270	1,6	160
		139 (16 PR)	2240	2,8	280	1,7	170
		139 (16 PR)	2430	3,2	320	1,9	190
		147 (22 PR)	2725	3,7	370	2,3	230
		147 (22 PR)	3075	4,2	420	2,6	260
365/80 R 20 14.5 R 20	MPT 81 MPT 80	132 (10 PR)	1950	2,1	210	1,1	110
		132 (10 PR)	1950	2,1	210	1,1	110
		143 (18 PR)	2120	2,3	230	1,3	130
		143 (18 PR)	2240	2,6	260	1,4	140
		143 (18 PR)	2430	2,9	290	1,6	160
		143 (18 PR)	2725	3,3	330	1,9	190
		152 (22 PR)	3075	3,7	370	2,3	230
		152 (22 PR)	3250	3,9	390	2,5	250
		152 (22 PR)	3550	4,4	440	2,8	280

Recommended load capacities for use on wheel loaders

Tyre size/Pattern		LI/SI	Type of use	Tyre load capacity (kg) at a pressure of					
				kPa	200	250	300	350	375
				150	2,0	2,5	3,0	3,5	3,75
				bar	2,0	2,5	3,0	3,5	3,75
				1,5	2,0	2,5	3,0	3,5	3,75
325/70 R 18	MPT 70 E	125 E	0 km/h break out	1880	2345	2785	3200	3615	3775
		125 E	10 km/h loading	1175	1465	1740	2000	2260	2360
		125 E	wheel loader VA+HA	1000	1245	1480	1700	1920	2010
365/70 R 18	MPT 70 E	133 E	0km/h break out	2325	2925	3475	4000	4550	4800
		133 E	10km/h loading	1450	1825	2175	2500	2850	3000
		133 E	wheel loader VA+HA	1225	1550	1850	2125	2425	2550
335/80 R 20	MPT 70 E	134 E	0km/h break out	2350	2950	3550	4125	4650	4925
		134 E	10km/h loading	1475	1850	2225	2575	2900	3075
		134 E	wheel loader VA+HA	1250	1575	1900	2200	2475	2625
365/80 R 20	MPT 70 E	139 E	0 km/h break out	2800	3525	4250	4875	5500	5850
		139 E	10 km/h loading	1750	2200	2650	3050	3450	3650
		139 E	wheel loader VA+HA	1500	1875	2250	2600	2925	3100
405/70 R 20	MPT 70 E	141 E	0 km/h break out	2950	3750	4475	5200	5900	6200
		141 E	10 km/h loading	1850	2350	2800	3250	3675	3875
		141 E	wheel loader VA+HA	1575	2000	2375	2775	3125	3300
455/70 R 24	MPT 70 E	152 E	0 km/h break out	3250	4340	5420	6520	7590	8170
		152 E	10 km/h loading	2050	2735	3420	4120	4790	5150
		152 E	wheel loader VA+HA	1630	2170	2710	3270	3800	4080

Technical data and load capacities MPT Diagonal

Size	Tyre			Rim	Tube and valve (TL-valve)	Normal dimensions in service		Continental tyre dimensions		Static radius	Rolling circumference Tol. ± 2,5 %
	PR	Operational code ¹⁾	Tread TL			width max.	outer dia. max.	width	outer dia.		
10.5-18 (275/80-18)	10	126 G	E 5	9 x 18	10.5/80-18 130/65-18 38 G 16 ²⁾	292	927	270	905	419	2660
12.5-18	12	132 E	MPT 30	11 x 18	12.5-18/ 14.5/80-18 38 G 16 ²⁾ (43GS16) ³⁾	351	1017	325	990	455	2910
10.5-20 (275/80-20)	10	128 G	MIL	9 x 20	(43GS16) ³⁾	292	977	270	955	440	2810
	14	134 G	Titan	9 x 20	(43GS16) ³⁾	292	977	270	955	440	2810
12.5-20 (335/80-20)	12	132 G	E 6	11 x 20 ⁴⁾ oder 11-20 SDC	10.5-20 38 G 16 ²⁾ (43GS16) ³⁾	351	1067	325	1040	480	3060
		132 E	MPT 30	11 x 20 ⁴⁾ oder 11-20 SDC	10.5-20 38 G 16 ²⁾ (43GS16) ³⁾	351	1067	325	1040	480	3060
14.5-20 (365/80-20)	10	132 G	E 6	11 x 20 oder 11-20 SDC	12.5-/14.5/ 16-20 38 G 16 ²⁾ (43GS16) ³⁾	383	1124	355	1095	503	3220
		132 E	MPT 30	11 x 20 oder 11-20 SDC	12.5-/14.5/ 16-20 38 G 16 ²⁾ (43GS16) ³⁾	383	1124	355	1095	503	3220
14.5-20 (365/80-20)	18	143 G	E 6	11-20 SDC	12.5-/14.5/ 16-20 38 G 16 ²⁾ (43GS16) ³⁾	383	1124	355	1095	503	3220
		143 E	MPT 30	11-20 SDC	12.5-/14.5/ 16-20 38 G 16 ²⁾ (43GS16) ³⁾	383	1124	355	1095	503	3220
16/70-20	14	148 D	MPT 30	13 x 20 SDC	–	440	1116	407	1076	495	3165

1) Load index single wheel fitment and speed index

2) Valve 47 GW optional

3) Valve 50 MSW optional

4) Over LI 132 please check rim load capacity

PR	Load-Index LI	Load capacity (kg) per tyre at tyre pressure Single tyre fitment										Speed index and ref. speed (km/h)	
		kPa	200	250	300	350	375	400	425	450	475		
		bar	2,0	2,5	3,0	3,5	3,75	4,0	4,25	4,5	4,75		
10	126	1000	1120	1360	1500	1630	1700	0					D (65), E (70), G (90)
12	132	1300	1450	1650	1800	2000							D (65), E (70), G (90)
10	128	1060	1170	1400	1550	1720	1800						D (65), E (70), G (90)
14	134	1060	1170	1400	1550	1720	1800	1875	1950	2030	2120		D (65), E (70), G (90)
12	132	1350	1480	1700	1850	2000							D (65), E (70), G (90)
12	132	1350	1480	1700	1850	2000							D (65), E (70), G (90)
10	132	1580	170	2000									D (65), E (70), G (90)
10	132	1580	170	2000									D (65), E (70), G (90)
18	132	1580	170	2000	2240	2430	2500	2575	2650	2725			D (65), E (70), G (90)
18	132	1580	170	2000	2240	2430	2500	2575	2650	2725			D (65), E (70), G (90)
14	148	-	-	-	2845	2990	3150						D (65), E (70), G (90)

Size range, specifications and tyre load capacities for use on industry vehicles

Size	Tyre				Rim	TL-valve Tube and valve (TL-valve)	Tyre dimensions Standard value			
	TL ¹⁾	Tread pattern	PR	Code ²⁾			max. in service		radius	rolling static circum- ference ± 2,5%
							Width	Outer dia.	± 2%	
Radial tyres acc. to DIN 7793/2 and WdK-Guideline 182/2										
10.5 R 20	•	MPT 80	10	128 J	9 x 20	43 GS 16	284	968	444	2865
	•	MPT 80	14	134 J	9 x 20	43 GS 16	284	968	444	2865
12.5 R 20	•	MPT 80	12	132 J	11 x 20 oder 11-20 SDC	43 GS 16 or 80 DS 80	340	1056	480	3120
	•	MPT 80	16	139 J			340	1056	480	3120
	•	MPT 80	22	147 J			340	1056	480	3120
14.5 R 20	•	MPT 80	10	132 J	11 x 20 oder 11-20 SDC	43 GS 16 or 80 D 80	373	1113	503	3285
	•	MPT 80	18	143 J			373	1113	503	3285
	•	MPT 80	22	152 J			373	1113	503	3285
315/55 R 16	•	MPT 81	–	120 K	10, 10DLB, 11	43 GS 11.5 43 GS 16	318	766	348	2282
	•	MPT 81	–	120 K	10, 10DLB, 11		329	766	348	2282
275/80 R 20	•	MPT 81	–	134 K	9, 9 SDC, W9	43 GS 16	292	966	440	2850
335/80 R 20	•	MPT 81	–	147 K	W 10, 11 11 SDC, W 11	43 GS 16	354	1066	480	3120
	•	MPT 81	–	147 K			386	1066	480	3120
365/80 R 20	•	MPT 81	–	152 K	11, 11 SDC, 12 SDC	43 GS 16	378	1118	502	3275
	•	MPT 81	–	152 K			389	1118	502	3275
325/70 R 18	•	MPT 70E	–	125 E	9, 11, 11 SDC	43 GS 16	328	940	423	2863
	•	MPT 70E	–	125 E	9, 11, 11 SDC	43 GS 16	350	940	423	2863
365/70 R 18	•	MPT 70E	–	133 E	11 SDC, 12	43 GS 16	400	1000	428	2895
	•	MPT 70E	–	133 E	11 SDC, 12	43 GS 16	411	1000	428	2895
335/80 R 20	•	MPT 70E	–	134 E	9, 11	43 GS 16	344	1076	480	3120
	•	MPT 70E	–	134 E	9, 11	43 GS 16	366	1076	480	3120
365/80 R 20	•	MPT 70E	–	139 E	11, 11SDC, 12	43 GS 16	378	1116	500	3302
	•	MPT 70E	–	139 E	11, 11SDC, 12	43 GS 16	389	1116	500	3302
405/70 R 20	•	MPT 70E	–	141 E	12, 13, 13 SDC	43 GS 16	441	1211	486	3227
	•	MPT 70E	–	141 E	12, 13, 13 SDC	43 GS 16	452	1211	486	3227

1) TT = Tube type
TL = Tubeless

2) Load Index for single wheel fitment and speed index

3) Over LI 132 please check rim load capacity

4) Valve 50 MSW optional

The minimum dual spacing is indicated on page 84

PR	Load index LI	Tyre pressure		Tyre load capacity (kg)							Size
		bar	kPa	Stationary	on other vehicles at max. speed (mph)				on fork lifts max. 16 mph		
					6	16	25	31	Load wheel	Steered wheel	
acc. to WdK-Guideline 151/11											
10	128	5.0	500	4500	3240	2430	2070	2015	3240	2700	10.5 R 20
14	134	6.5	650	5300	3815	2860	2440	2375	3815	3180	
12	132	4.25	425	5000	3600	2700	2300	2240	3600	3000	12.5 R 20
16	139	5.5	550	6075	4375	3280	2795	2720	4375	3545	
22	147	8.0	800	7690	5535	4150	3535	3445	5535	4610	
10	132	5.5	550	6810	4905	3680	3135	3050	4905	4090	14.5 R 20
18	143	5.5	550	6810	4905	3680	3135	3050	4905	4090	
22	152	7.0	700	8875	6390	4790	4080	3975	6390	5325	
-	120	4.20	420	3500	2520	1890	1610	1570	2520	2030	315/55 R 16
-	120	4.20	420	3500	2520	1890	1610	1570	2520	2030	
-	134	6.50	650	5300	3815	2860	2440	2375	3815	3180	275/80 R 20
-	147	8.00	800	7690	5535	4150	3535	3445	5535	4610	335/80 R 20
-	147	8.00	800	7690	5535	4150	3535	3445	5535	4610	
-	152	7.0	700	8875	6390	4790	4080	3975	6390	5325	365/80 R 20
-	152	7.0	700	8875	6390	4790	4080	3975	6390	5325	
-	125	4.25	425	4125	2970	2230	1900	1850	2970	2390	325/70 R 18
-	125	4.25	425	4125	2970	2230	1900	1850	2970	2390	
-	133	4.25	425	5150	3710	2780	2370	2300	3710	2990	365/70 R 18
-	133	4.25	425	5150	3710	2780	2370	2300	3710	2990	
-	134	4.25	425	5300	3820	2860	2340	2375	3820	3070	335/80 R 20
-	134	4.25	425	5300	3820	2860	2340	2375	3820	3070	
-	139	4.25	425	6010	4375	3280	2795	2720	4370	3520	365/80 R 20
-	139	4.25	425	6010	4375	3280	2795	2720	4370	3520	
-	141	4.25	425	6440	4635	3475	2960	2885	4640	3730	405/70 R 20
-	141	4.25	425	6440	4635	3475	2960	2885	4640	3730	

Size range, specifications and tyre load capacities for use on industry vehicles

Size	Tyre				Rim	TL-valve Tube and valve (TL-valve)	Tyre dimensions Standard value			
	TL ¹⁾	Tread pattern	PR	Code ²⁾			max. in service Width	radius Outer dia.	± 2%	rolling static circum- ference ± 2,5%
Crossply tyres acc. to DIN 7793/1 and WdK-Guideline 182/1										
10.5-18 (275/80-18)	•	E 5	10	126 G	9x18	10.5/80-18 10.5-18 13.0/65-18 38 G 16	292	927	419	2660
12.5-18	•	MPT 30	12	132E	11x18	(43 GS 16) ⁴⁾ 12.5/14.5/80-18 38 G 16 47 G W	351	1017	455	2910
10.5-20 (275/80-20)	•	MIL	10	128 G	9x20	10.5-20 38 G 16 47 G W 93 G 16	292	977	444	2805
	•	Titan	14	134 G	9x20	10.5-20 38 G 16 47 G W 93 G	292	977	444	2805
12.5-20 (335/80-20)	•	MPT 30	12	132 E	11 x 20 ³⁾ oder 11-20 SDC	(43 GS 16) ⁴⁾ 12.5/ 14.5/16-20 38 G 16 47 G W 75 D 150 D	351	1067	480	3055
	•	E 6	12	132 G	11 x 20 ³⁾ oder 11-20 SDC		351	1067	480	3055
14.5-20 (365/80-20)	•	E6	10	132 G	11 x 20 ³⁾ oder 11-20 SDC	(43 GS 16) ⁴⁾ 12.5/ 14.5/16-20 38 G 16 47 G W 75 D 150 D	383	1124	503	3215
	•	MPT 30	10	132 E	11 x 20 ³⁾ oder 11-20 SDC		383	1124	503	3215
14.5-20 (365/80-20)	•	E6	18	143 G	11-20 SDC		383	1124	503	3215
	•	MPT 30	18	143 E	11-20 SDC		383	1124	503	3215

1) TT = Tube type
TL = Tubeless

2) Load Index for single wheel fitment and speed index

3) Over LI 132 please check rim load capacity

4) Valve 50 MSW optional

The minimum dual spacing is indicated on page 84.

PR	Load index LI	Tyre pressure		Tyre load capacity (kg)							Size
		bar	kPa	Stationary	on other vehicles at max. speed (mph)				on fork lifts max. 16 mph		
					6	16	25	31	Load wheel	Steered wheel	
acc. to WdK-Guideline 151/11											
10	126	4,5	450	4250	3060	2295	1955	1905	3060	2550	10.5-18 (275/80-18)
12	131	4,25	425	4875	3510	2630	2240	2185	3510	2925	12.5-18
10	128	4,5	450	4500	3240	2430	2070	2015	3240	2700	10.5-20 (275/80-20)
14	134	5,75	575	5300	3815	2860	2440	2375	3815	3180	
12	132	4,25	425	5000	3600	2700	2300	2240	3600	3000	12.5-20 (335/80-20)
12	132	4,25	425	5000	3600	2700	2300	2240	3600	3000	
10	132	3,0	300	5000	3600	2700	2300	2240	3600	3000	14.5-20 (365/80-20)
10	132	3,0	300	5000	3600	2700	2300	2240	3600	3000	
18	143	5,5	550	6810	4905	3680	3130	3050	4900	4085	14.5-20 (365/80-20)
18	143	5,5	550	6810	4905	3680	3130	3050	4900	4085	

EM (OTR) Tyres

General Characteristics

EM (OTR) Tyres are extremely resistant to damage and achieve excellent traction even on difficult terrain. EM (OTR) Tyres are designed for off-road applications.

Special applications by construction

Radial:

- enhanced mileage
- good ride comfort
- high speed rating
- increased traction

Cross-ply:

- good vehicle stability
- good self-cleaning on muddy ground
- damage resistant sidewall

Suitable vehicles

- | | |
|-----------------------|------------------|
| · graders | · loaders |
| · articulated dumpers | · rigid dumpers |
| · bulldozers | · scrapers |
| · compactors | · mobile diggers |
| · digger loaders | · mobile cranes |

General applications

- | | |
|------------------------|-------------------|
| · gravel and sand pits | · quarries |
| · mining | · municipal yards |
| · factories | · road buildin |

Operating instructions (DIN 7798 und 7799, WdK LL 145 und 146/1)

Load capacity and speed

When determining the minimum tyre size necessary for a vehicle, the approved wheel load and the maximum design speed of the vehicle should always be used as a basis.

The so-called "list of tolerances" must also be considered. Nominal load capacity = 100% load, as indicated by the Load Index (LI).

Tyre pressure

The pressures given in the tables are minimum ones and serve as guidelines. In some cases, suitable pressures are recommended for special operating conditions.

Rims

Only the rims detailed in this book may be fitted for use on the tyres shown.

Wheels

The load capacity of the wheels used must always be adequate.

Knurlings

When fitting tubeless tyres on wheels with knurlings for the first time, make sure that the fit is airtight.

If subsequent fittings have to be undertaken, e.g. after a repair, bead sealing rings must be used.

Speed categories

EM and low profile EM tyres	up to 31 mph (50 km/h)
Tractor Grader tyres	up to 25 mph (40 km/h)
Sand Service tyres	up to 70 km/h

Tyre load capacity in special applications

Application conditions (DIN 7798)

Loading

Loading is a term which covers the loosening of earth, stones, etc., by the shovel of a vehicle, as well as the picking up and dumping of goods onto vehicles, in processing facilities, on stockpiles/dumps or on building sites. The tyre load capacities and pressures given in the table are based on a speed of around 6 mph (10 km/h) and a distance of about 100 m.

Transport

Transport is the conveying process in which the machine or the vehicle carries a load over a reasonably long distance to the unloading point, after loading the cargo itself or receiving the cargo from some kind of loading device. The machine/vehicle generally returns unloaded to the prospecting/loading point.

Scrapers and trough vehicles are used for work of this kind.

The load capacities and pressures given in the tables from page 90 onwards, found under “31 mph (50 km/h)” and in the table on this page under “transporting”, apply to carrying and empty running distances of a maximum of 2.5 miles (4 km). If longer distances are involved, please contact us for further information.

Loading and transport using wheel loaders

Loading and transport means the movement of goods on wheel loaders in which, after the earth, etc., is “loosened”, it is picked up and carried away immediately. The carrying distance is generally several hundred metres at maximum speeds of between 9 mph (15 km/h) and 16 mph (25 km/h).

The speed of a haul is between 5 mph (8 km/h) and 10 mph (16 km/h).

The permissible tyre load capacities are between the values given in the table for the application conditions “31 mph (50km/h)” and “Loading”.

The fitting of special tyres may be necessary to meet the demands placed on the wheel loader as a result of these applications. Please contact us for further details on the appropriate tyres and the permitted application conditions (load capacity and pressure).

Journeys to place of use

To protect the generally thick-walled EM tyre against over heating or other damage, the following should be observed in respect to journeys (to the place of use) made by the machine or vehicle running on its own axles (self-propelled or towed): prior to all journeys, the tyre pressure should be increased by 30% and during such trips, the machine/vehicle must not carry any load.

For safety reasons during journeys, there should be a cooling-off period after each hour of the journey.

Construction vehicle operations

Tyre load capacities for transporting at other speeds			
Maximum speed *)		Tyre load capacity in % of the values for transporting	
mph	km/h	References peed 31 mph (50km/h)	
10	15	112	
12	20	110	
16	25	108	
19	30	106	
22	35	104	
25	40	103	
28	45	102	
31	50	100	
		Low-profile tyre	Standard aspect ratio tyre
34	55	97	98
37	60	92	93
40	65	83	85

*) Please get in touch with us for speeds below 15 km/h or above 65 km/h.

Core features

Customer benefits

R 74 (Code E3)

Crossply - EM (OTR)



This Standard EM (OTR) tyre has a robust tread pattern combined with effective tread blocks for vehicles with high axle loads.

- robust crossply casing
- resistant to sidewall puncture
- good damping characteristics

E 58 (Code E2/L2)

Crossply - EM (OTR)



The high-traction tread pattern for unsurfaced ground. Available in size 20-24 (22/70-24).

- strong, wear resistant lugs
- open, directionally-orientated tread lugs
- good mileage
- good traction
- excellent mobility on soft terrain

LC 100 (Code L3)

Crossply - EM (OTR)



The universal EM (OTR) tyre for a wide range of applications.

- balanced tread ratio
- good mobility on soft terrain
- good mileage on solid ground

Core features

Customer benefits

E 7 RIB (Code E7)

Crossply - EM (OTR)



This EM (OTR) tyre is made specially for use on sand, i.e. for vehicles in desert service and trucks in road construction. Available in size 18-20.

- low air pressure through high air volume
- good mobility on unpacked ground, especially sand

E 7 GRIP (Code E3)

Crossply - EM (OTR)



This EM (OTR) tyre is designed for grader sand use. Available in size 22-20.

- special tread pattern
- no carving of surface on loose ground
- low air pressure through high air volume
- good mobility on unpacked and soft grounds, especially sand

Technical data

Tyre						Rim	Tube	New				in operation	Radius Static	Rolling circumference
Size	Tread	PR	LI	TT	TL		Valve Flap	Cross section width	Outer dia.	Width max.	Outer dia. max.	± 2%	± 2,5%	
14.00-24	For replacement R74 in SIMEX tread pattern see separate SIMEX data sheet													
16.00-25	R74	28	174 B		●	11.25-25/2.0	schlauchlos 80 DS 80	432	1493	480	1561	687	4330	
	R74	28	174 B		●	13.00-25/2.0	schlauchlos 80 DS 80	450	1493	498	1561	687	4330	
18.00-25	For replacement R74 in SIMEX tread pattern see separate SIMEX data sheet													
15.5-25	LC100	12	149 B		●	12.00-25/1.3	50 MSW	394	1277	437	1328	590	3705	
17.5-25	LC100	16	158 B		●	14.00-25/1.5	50 MSW	445	1348	494	1405	620	3910	
20-24	E58	12	158 B		●	16.00T-24SDC	80 DS 80	545	1390	585	1452	633	4030	
20.5-25	LC100	16	167 B		●	17.00-25/1.7/2.0	80 DS 80	520	1492	577	1561	682	4330	
	LC100	20	170 B		●		80 DS 80	520	1492	577	1561	682		
23.5-25	LC100	16	171 B		●	19.50-25/2.5	80 DS 80	597	1617	663	1696	734	4690	
	LC100	20	177 B		●		80 DS 80	597	1617	663	1696	734		
26.5-25	LC100	28	188 B		●	22.00-25/3.0	80 DS 80	673	1750	747	1834	791	5080	
	LC100	28	188 B		●		80 DS 80	673	1750	747	1834	791		

Load capacities

PR	Tyre load capacity (kg) at pressure											Speed km/h	Tyre size
	kPa	200	275	425	500	575	650	700	750	850	(925)		
	150	2,0	2,75	4,25	5,0	5,75	6,5	7,0	7,5	8,5	(9,25)		
	For replacement R74 in SIMEX tread pattern see separate SIMEX data sheet												14.00–24
28	7160	8510	10300	13200	14600	15900	17000	17800	18400			0	16.00–25
	4480	5330	6450	8250	9150	9950	10600	11100	11500			Loading ¹⁾	
	3060	3630	4400	5650	6200	6700						50	
	For replacement R74 in SIMEX tread pattern see separate SIMEX data sheet												18.00–25

12	6400	6800	7150	7500	7800	8160	8560	8960					0	15.5–25	
	4000	4250	4475	4875	4875	5100	5350	5600					Loading ¹⁾		
	3000	3250											50		
16	7600	8100	8550	9850	9450	9850	10200	10600	11040	11400	11700		0	17.5–25	
	4750	5050	5350	5600	5900	6150	6400	6650	6900	7100	7300		Loading ¹⁾		
	3650	3850	4050	4250									50		
12	8095	8875	9640	10400									0	20–24	
	5060	5545	6025	6500									Loading ¹⁾		
	3905	4250											50		
16	10100	10700	11400	12000	12600	13200							0	20.5–25	
	6300	6700	7100	7500	7900	8250							Loading ¹⁾		
	4825	5150	5450										50		
20							13800	14240	14720	15200			0	20.5–25	
							8600	8900	9200	9500			Loading ¹⁾		
				5750	6000								50		
16	12800	13800	14400	15200									0	23.5–25	
	8000	8500	9000	9500									Loading ¹⁾		
	6150												50		
20					16800	16600	17400						0	23.5–25	
					7950	10400	10400						Loading ¹⁾		
		6550	6950	7300									50		
28							21760	22400	32200	24000	24800		0	26.5–25	
							13600	14000	14500	15000	15500		Loading ¹⁾		
		7800	8250	8750	9250	9630	10000						50		
32												25600	26400	27200	0
												16000	16500	17000	Loading ¹⁾
							10400	10800	11200					50	

1) Loading is a term which covers the loosening of earth, stones, etc., by the shovel of a vehicle, as well as the picking up and dumping of goods onto vehicles, in processing facilities, on stockpiles/dumps or on building sites. The tyre load capacities and pressures given in the table are based on a speed of around 6 mph (10 km/h) and a distance of about 100 m.

Technical data

Tyre						Rim	Tube and valve (TL Ventil)	Tyre dimensions				Radius Static ± 2%	Rolling circumference ± 2,5%
Größe	Profil	PR	Betriebs- kennung	TT	TL			Max. value in service width	outer dia.	new width	outer dia.		
18-20	E7 RIB	8	140 D		•	14 x 20	18-20 T 57 GW (50 MSW) (43 GS 16)	518	1095	485	1070	485	3085
22-20	E7 GRIP	12	152 E		•	17 x 20	(50 MSW) (43 GS 16)	605	1110	560	1055	463	3080

Load capacities

Tyre size	Load capacity (kg) per axle single tyre fitment	Tyre pressure for use on					
		Road 40 mph (65 km/h)		Truck 31 mph (50 km/h)		Sand 9 mph (15 km/h)	
		bar	kPa	bar	kPa	bar	kPa
18-20 8 PR	5000	2,7	270	2,2	220	1,6	160
	4500	2,4	240	1,9	190	1,4	140
	4000	2,1	210	1,6	160	1,2	120
	3500	1,8	180	1,3	130	1,0	100
	3000	1,5	150	1,0	100	0,8	80
	2500	1,2	120	0,8	80	0,8	80
22-20 12 PR	7000	3,6	360	3,2	320	2,4	240
	6000	3,0	300	2,6	260	2,0	200
	5000	2,5	250	2,2	220	1,7	170
	4000	2,0	200	1,6	160	1,4	140
	3000	1,6	160	1,2	120	1,0	100
	2500	1,2	120	0,8	80	0,8	80

Explanations and operating conditions for rims

The rim is the part of the wheel which supports the tyre.

1. Important elements of the rim

- Rim
- flange = lateral support for the tyre bead
 - flange distance = rim width
 - bead seat = base on which the tyre is seated
 - base = inner side of the rim
 - diameter = cornerpoint

2. Main types of rim

Well-base rim = one-piece; deeper well for easier tyre fitting (5° tapered bead) (“x” in wheel size designation)

Semi drop centre rim = split; the base is slightly deeper (5° tapered) (SDC designation of the wheel = Semi Drop Centre)

Tapered bead seat rim = split; flat base (usually 5° tapered bead seat) (“-” in the wheel designation)

Flat base rim = split; flat base (bead seat approx. 0°) (with reference letter for flange shape in designation)

3. Wheel disc

The wheel disc is the linking element between the rim and the axle hub.

Of all the measurements for wheel linking elements – centre bore, diameter of pitch circle, wheel studbore and wheel disc offset – the latter is an important size for the free movement of the tyre in any wheel position. Wheel disc offset = 0, when the rim centre and the hub face of the wheel disc are inline.

One speaks of inset when the inner face of the wheel disc is displaced outwards from the centre of the wheel and of outset when the displacement is to the inside of the wheel.

4. Wheel strength

For special cases the adequate wheel strength must be approved by the wheel manufacturer.

5. Lateral and true running of the wheels

Both on fast vehicles and on large heavy wheels it is particularly important that the wheels are well-centred.

Especially on faster vehicles there should be as little radial and lateral run-out as possible on both bead seat/flange sides of the rim, in order to achieve good smooth running.

For fast commercial vehicles, both light and heavy, particularly low radial run-out values for example may be necessary and these will be considerably below the specified standard maximum values.

6. Testing ring diameter d_2 and circumference U

Values for calibration by ball-measuring tape.

Rims for industrial vehicles acc. to DIN 7825

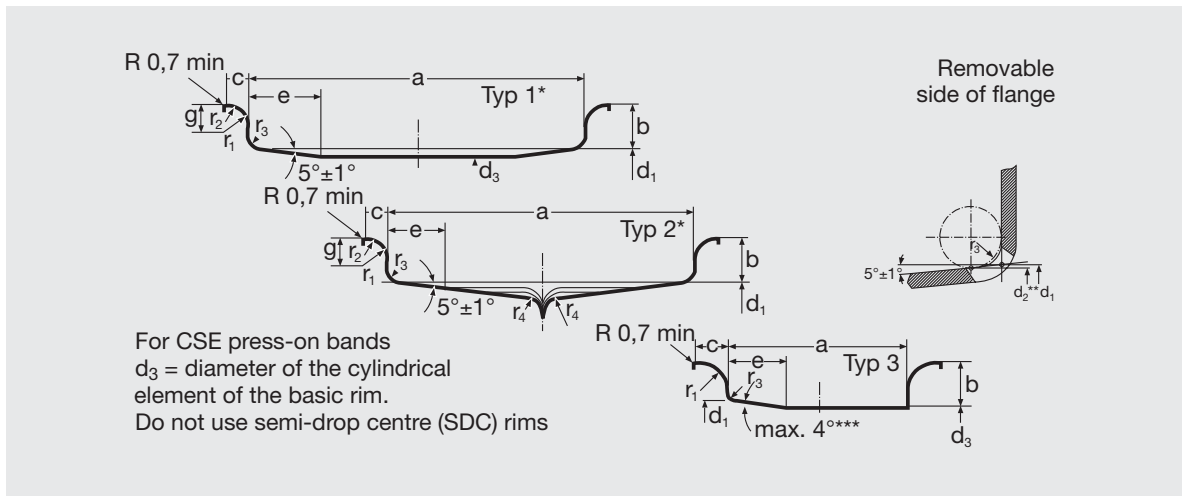

Size	Rim		Testingring		Rim width		Flange dimensions								Type
	d_1 Ø	d_3 Ø	** d_2 Ø	U $p \cdot d_2$ $\pm 1,2$	a Perm. dev.	b Perm. dev.	c min.	g =	r_1 =	e min.	r_2 max.	r_3 max.	r_4 max.		
2.10-4	100,8	-	100,1	314,6	53,3 ± 1,6	11,9 ± 0,5	8	-	7	12,5	-	3,2	5	2	
2.50 C-4	100,8	-	100,1	314,6	63,5 ± 1,6	16	10,4	11,5	12	11	3,5	3,2	5	2	
4.50 E-6	151,6	-	151,1	474,7	114,3 ± 1,6	19,8	13,1	-	10	-	-	6,0	7	2	
3.00 D-8	202,4	197,5	201,7	633,8	76,2 ± 1,6	17,5	11,5	12,4	13	14,2	8,1	4,3	-	1*	
	202,4	197,5	201,7	633,8	76,2 ± 1,6	17,5	11,5	12,4	13	14,2	8,1	4,3	5	2*	
31/4I-8	202,4	197,5	201,7	633,8	82,5 ± 1,6	15,7	9,7	-	8,9	-	-	4,3	7,9	2	
4.33 R-8	204,4	202,4	203,9	640,8	110 ± 2,3	28,6 ± 1,6	21,5	-	18	34	-	6,4	-	3	
4.00 E-9	227,8	222,9	227,1	713,6	101,6 ± 1,6	19,8	11,7	13,6	14,2	28	8,6	6,4	-	1*	
	227,8	222,9	227,1	713,6	101,6 ± 1,6	19,8	11,7	13,6	14,2	28	8,6	6,4	10	2*	
5.00 F-10	253,2	246,8	251,8	791,3	127 ± 1,6	22,2	12,2	14,5	15,6	23,8	9,5	6,4	-	1*	
	253,2	246,8	251,8	791,3	127 ± 1,6	22,2	12,2	14,5	15,6	23,8	9,5	6,4	11	2*	
5.00 S-12	308,8	301,3	307,4	965,8	127 ± 1,6	31,3 ± 1,2	18,3	-	18,3	43	-	8,0	-	1*	
	308,8	301,3	307,4	965,8	127 ± 1,6	31,3 ± 1,2	18,3	-	18,3	43	-	8,0	15,8	2*	
5.50 F-10	253,2	246,8	251,8	791,3	139,7 ± 1,6	22,2	12,2	14,5	15,6	34	9,5	6,4	-	1*	
	253,2	246,8	251,8	791,3	139,7 ± 1,6	22,2	12,2	14,5	15,6	34	9,5	6,4	11	2*	
6.00 E-9	227,8	222,9	227,1	713,6	152,4 ± 1,6	19,8	11,7	13,6	14,2	28	8,6	6,4	-	1	
6.50 F-10	253,2	246,8	251,8	791,3	165,1 ± 1,6	22,2	12,2	14,5	15,6	34	9,5	6,4	-	1	
8.00 G-12	304,0	296,6	302,6	950,9	203,2 ± 2,5	27,9	14	-	14	40,6	-	7,5	-	1	
10.00 G-12	304,0	296,6	302,6	950,9	254 ± 3,0	27,9	14	-	14	40,6	-	7,5	-	1	
3.11 F-13	334,0	330,2	333,2	1046,7	79 ± 1,5	22 ± 1	12,2	-	16	25	-	5,5	-	3	
3.75P-13	334,0	330,2	333,2	1046,7	95,2 ± 2,3	25,4 ± 1,5	19,1	-	16	25	-	6,4	-	3	

* Rim type 1 or 2 at manufacturer's choice.

** Diameter of measuring ball 8 mm for rims 2.10/2.50 C/3.00 D/4.00 E/6.00 E, for all others 16 mm Ø.

*** Rim 4.33 R - 8 1°30'.

Tapered base rims to DIN 7820 requirements for commercial vehicles and industrial trucks

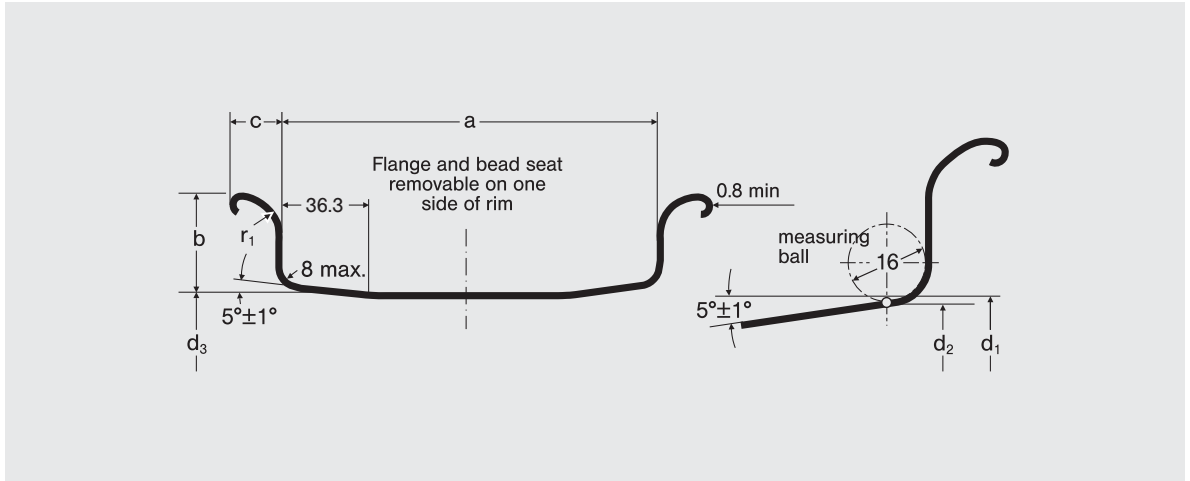

Rim Size	Testing ring			Rim								
	d_1 ø	d_2 ø	U $\pi \cdot d_2$ $\pm 1,2$	d_3 ø	a		Usual version			Special version		
					Nominal value	Perm. dev.	b $\pm 1,2$	c min	r_1 $\pm 2,5$	b ± 1	c min	r_1 $\pm 2,5$
5.0-20	514,4	513,01	1611,7	508	127,0	$\pm 2,5$	27,9	16,5	14,0			
5.5-15	387,4	386,01	1212,7	381	139,7	$\pm 2,5$	30,5	17,8	15,2			
6.0-15	387,4	386,01	1212,7	381	152,4	$\pm 2,5$	33,0	19,1	16,5			
6.0-20	514,4	513,01	1611,7	508	152,4	$\pm 2,5$	33,0	19,1	16,5			
6.5-15	387,4	386,01	1212,7	381	165,1	$\pm 2,5$	35,6	20,4	17,8			
6.5-20	514,4	513,01	1611,7	508	165,1	$\pm 2,5$	35,6	20,4	17,8	36,8	21,0	18,4
7.0-15	387,4	386,01	1212,7	381	177,8	$\pm 2,5$	38,1	21,6	19,0			
7.0-20	514,4	513,01	1611,7	508	177,8	$\pm 2,5$	38,1	21,6	19,0	36,8	21,0	18,4
7.5-15	387,4	386,01	1212,7	381	190,5	$\pm 3,0$	40,6	22,9	20,3			
7.5-20	514,4	513,01	1611,7	508	190,5	$\pm 3,0$	40,6	22,9	20,3	42,0	23,5	21,0
8.0-15	387,4	386,01	1212,7	381	203,2	$\pm 3,0$	43,2	24,2	21,6			
8.0-20	514,4	513,01	1611,7	508	203,2	$\pm 3,0$	43,2	24,2	21,6	42,0	23,5	21,0
8.5-20	514,4	513,01	1611,7	508	215,9	$\pm 3,5$	45,7	25,4	22,9			
8.5-24	616,0	614,61	1930,8	609,6	215,9	$\pm 3,5$	45,7	25,4	22,9			
9.0-20	514,4	513,01	1611,7	508	228,6	$\pm 3,5$	48,3	26,7	24,1	45,7	25,4	22,9
9.75-15	387,4	386,01	1242,7	381	247,65	$\pm 2,5$	38,1	21,6	19,0			
10.0-20	514,4	513,01	1611,7	508	254,0	$\pm 5,0$	50,8	28,0	25,4			
10.0-22	565,2	563,81	1771,3	558,8	254,0	$\pm 5,0$	50,8	28,0	25,4			
10.0-24	616,0	614,61	1930,8	609,6	254,0	$\pm 5,0$	50,8	28,0	25,4			
14.0-20	514,4	513,01	1611,7	508	355,6	$\pm 5,0$	45,7	25,4	22,9			

For CS press-on bands d_3 = diameter of the cylindrical element of the basic rim. Do not use semi-drop-centre (SDC) rims.

Semi drop centre rims acc. to DIN 7826 and WdK-Guideline 28 for Commercial, All-purpose and Earth moving vehicles

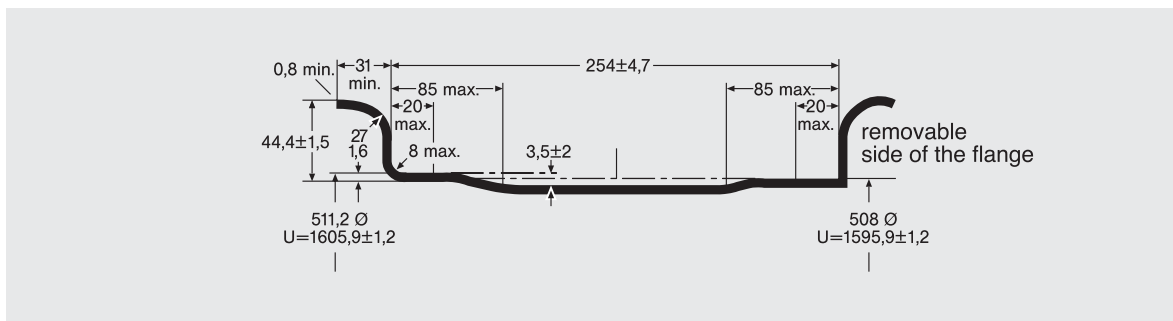
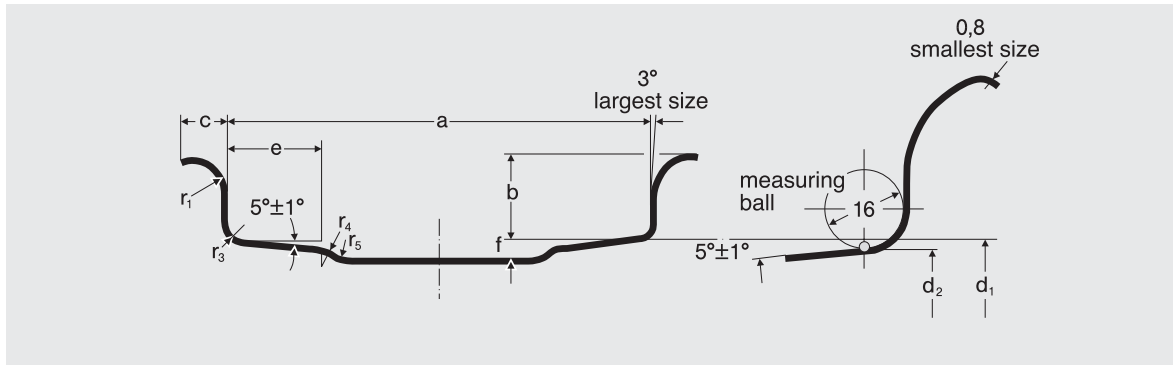

Rim Size	Testing ring			Rim									
	d_1 \varnothing	d_2 \varnothing	U $\pm 1,2$	a Nominal value	a Perm. dev.	e min.	f min.	r_3 max.	r_4 ca.	r_5 ca.	b $\pm 1,2$	c min.	r_1 $\pm 2,5$
6.00 G-16 SDC	405,6	404,27	1270,0	152,4	$\pm 3,2$	31,8	5,5	7,1	9,5	9,5	12,9	16	14
6.50 H-16 SDC	405,6	404,27	1270,0	165,1	$\pm 3,2$	36,3	5,5	7,1	8	6,5	12,9	16	14
11-20 SDC	512,8	511,42	1606,7	279,4	± 5	50	10	8,0	13	10	25,4	13	11
12-20 SDC	512,8	511,42	1606,7	304,8	± 6	50	10	8,0	13	10	25,4	13	11
13-20 SDC	512,8	511,42	1606,7	330,2	± 6	50	10	8,0	15	10	25,4	13	11
8.00 TC-24 SDC	614,4	613,02	1925,9	203,2	$\pm 3,2$	47	6,7	8,0	13		35,7	16,5	16,7
10.00 VA-24 SDC	614,4	613,02	1925,9	254,0	± 5	59	11	8,0	13	9,5	43,2	24,5	22,9
16.00 T-24 SDC	614,4	613,02	1925,9	406,4	$\pm 12,7$	50	12,7	8,0	-	-	35,7	22	22,7
10.00 V-20	-												

Rims acc. to DIN 7848 for earth-moving equipment

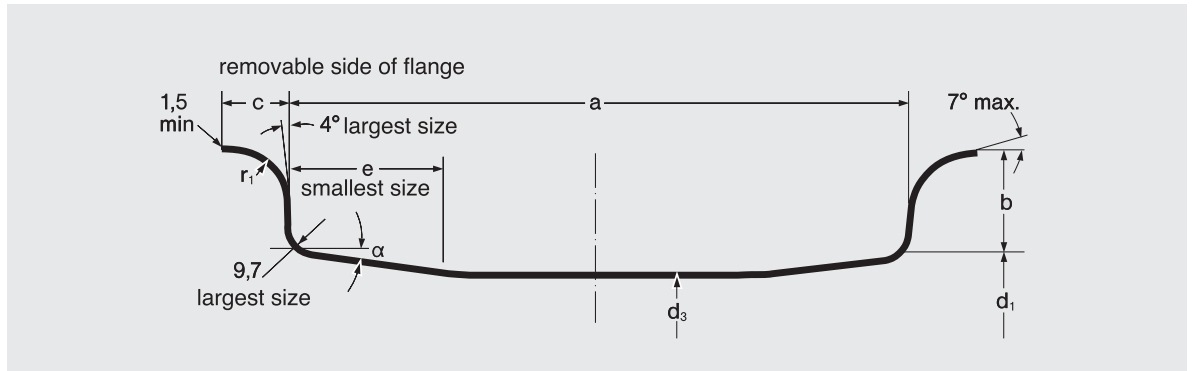

Size	d ₁	U $\pi \cdot d_1$ + 1,2 - 2,4	d ₃ + 0,4 - 12,7	a ± 12,7	b ± 1,6	c min.	e min.	r ₁		α ± 1°
								Nominal value	Perm. dev.	
11.25-25/2,0	635,0	1994,9*)	609,6	285,8	50,8	31,5	101	31,8	± 1,5	5
12.00-25/1,3	635,0	1994,9*)	609,6	304,8 ± 6,4	33,0	24,5	60	22,9	± 1,3	5
13.00-25/2,0	635,0	1994,9*)	609,6	330,2	50,8	31,5	101	31,8	± 1,5	5
13.00-25/2,5	635,0	1994,9*)	609,6	330,2	63,5	46,5	101	38,1	± 1,5	5
14.00-25/1,5	635,0	1994,9*)	609,6	355,6 ± 6,4	38,1	27,0	60	25,4	± 1,3	5
15.00-25/2,5	635,0	1994,9*)	609,6	381,8	63,5	41,5	101	38,1	± 1,5	5
17.00-25/1,7	635,0	1994,9*)	609,6	431,8	43,2	24,5	60	22,9	± 1,3	5
17.00-25/2,0	635,0	1994,9*)	609,6	431,8	50,8	24,5	101	31,8	± 1,5	5
19.50-25/2,5	635,0	1994,9*)	609,6	495,3	63,5	44,5	101	38,1	± 1,5	5

*) Rims 12.00 and 14.00 nominal mandrel circumference = 1989.7 mm with 20 mm ball.

Well-base rims according to DIN 7818 for light commercial and agricultural vehicles

Symmetrical well base rim
3.00 D to 5.50 F

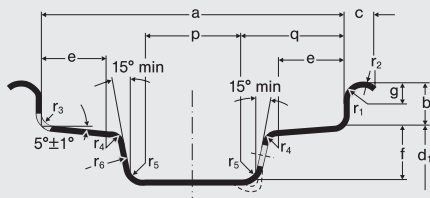

Asymmetrical well base rim
5.50 F to 6.00 F

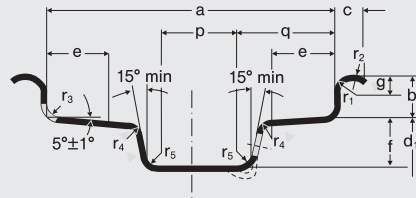

Rim size	d ₁	d ₂	U	a	b	c		e	f	g	p	q	r ₁	r ₂	r ₃	r ₄	r ₅	r ₆
						Nom. value	Perm. value											
3.00 D x 14	354,8	353,47	1110,5	76,2	17,5	12,2	+3,3 0	14,2	18,0	12,4	17,8	28,7	13,0	8,1	6,4	6	10	31,8
3.00 D x 15	380,2	378,87	1190,2	76,2	17,5	12,2	+3,3 0	14,2	18,0	12,4	17,8	28,7	13,0	8,1	6,4	6	10	31,8
3.00 D x 16	405,6	404,27	1280,0	76,2	17,5	12,2	+3,3 0	14,2	18,0	12,4	17,8	28,7	13,0	8,1	6,4	6	10	31,8
3.50 D x 16	405,6	404,27	1280,0	88,9	17,5	12,2	+3,3 0	15,7	18,0	12,4	17,8	34,0	13,0	8,1	6,4	6	10	34,9
4.00 E x 16	405,6	404,27	1280,0	101,6	19,8	12,4	+4,1 0	18,0	19,9	13,6	17,8	35,0	14,2	8,6	6,4	6	10	38
4.50 E x 16	405,6	404,27	1280,0	114,3	19,8	12,4	+4,1 0	18,0	23,4	13,6	22,0	39,7	14,2	8,6	6,4	6	10	-
4.00 E x 18	462,0	460,62	1447,1	101,6	19,8	12,4	+4,1 0	18,0	19,0	13,6	19,0	35,0	14,2	8,6	6,4	6	10	38
4.00 E x 19	487,4	486,02	1526,9	101,6	19,8	12,4	+4,1 0	18,0	19,0	13,6	19,0	35,0	14,2	8,6	6,4	6	10	38
4.50 E x 19	487,4	486,02	1526,9	114,3	19,8	12,4	+4,1 0	18,0	23,4	13,6	22,0	39,7	14,2	8,6	6,4	6	10	
4.50 E x 20	512,8	511,42	1606,7	114,3	19,8	12,4	+4,1 0	18,0	23,4	13,6	22,0	39,7	14,2	8,6	6,4	6	10	
5.00 F x 16	405,6	404,27	1270,0	127	22,2	12,9	+2,3 0	23,9	27,6	14,5	25,4	54,0	15,6	9,7	6,4	6	10	
5.00 F x 18	462,0	460,62	1447,1	127	22,2	12,9	+2,3 0	23,9	27,6	14,5	25,4	54,0	15,6	9,7	6,4	6	10	
5.00 F x 19	487,4	486,02	1526,9	127	22,2	12,9	+2,3 0	23,9	27,6	14,5	25,4	54,0	15,6	9,7	6,4	6	10	
5.00 F x 20	512,8	511,42	1606,7	127	22,2	12,9	+2,3 0	23,9	27,6	14,5	25,4	54,0	15,6	9,7	6,4	6	10	
5.50 F x 15	380,2	378,97	1190,2	139,7	22,2	12,9	+2,3 0	23,9	27,6	14,5	25,4	54,0	15,6	9,7	6,4	6	10	
5.50 F x 16	405,6	404,27	1270,0	139,7	22,2	12,9	+2,3 0	23,9	27,6	14,5	25,4	54,0	15,6	9,7	6,4	6	10	
5.50 F x 18	462,0	460,62	1447,1	139,7	22,2	12,9	+2,3 0	23,9	27,6	14,5	25,4	54,0	15,6	9,7	6,4	6	10	
5.50 F x 20	512,8	511,42	1606,7	139,7	22,2	12,9	+2,3 0	23,9	27,6	14,5	25,4	54,0	15,6	9,7	6,4	6	10	
6.00 F x 16	405,6	404,27	1270,0	152,4	22,2	12,9	+2,3 0	23,9	28,6	14,5	25,4	54,0	15,6	9,7	6,4	6	10	

Well-base rims according to DIN 7817 for light commercial vehicles Symmetrical and asymmetrical versions

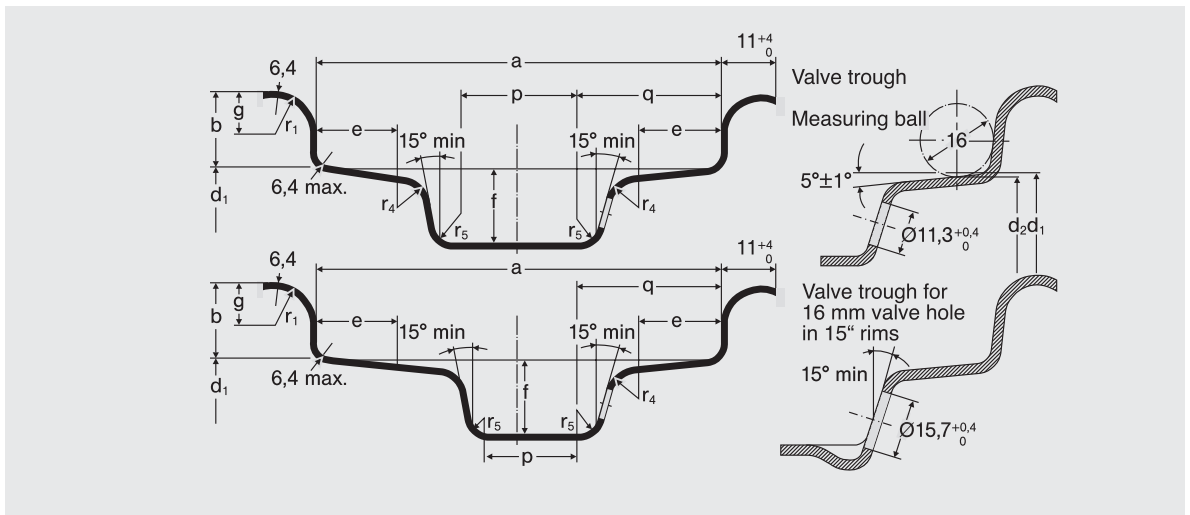

Size	Rim										Rim		Testing ring	
	a ± 1,5	b ± 1,2 - 0,4	e min. *)	f min.	g	p min.	q max.	r ₁	r ₄ min.	r ₅ ± 3	Code ø	d ₁ ø	d ₂ ø	U ± 1,2 - 0,9
4 1/2 J	114,3	17,3	22	17,8	9,7	22	45	9,7	8	7	13	329,4	328,07	1030,7
5 J	127,0	17,3	22	17,8	9,7	22	45	9,7	8	7	14	354,8	353,47	1110,5
5 1/2 J	139,7	17,3	22	17,8	9,7	22	45	9,7	8	7	15	380,2	378,87	1190,2
6 J	152,4	17,3	22	17,8	9,7	22	45	9,7	8	7	16	405,6	404,27	1270,0
6 1/2 J	139,7	17,3	22	17,8	9,7	22	45	9,7	8	7	17	436,6	435,22	1367,3
4 1/2 K	114,3	19,6	22	20,3	10,3	22	45	10,7	9,5	7	*) on hump rims the measurement e is the hump distance with + 1.0 tolerance			
5 1/2 K	139,7	19,6	22	20,3	10,3	22	45	10,7	9,5	7				
6 1/2 K	165,1	19,6	22	20,3	10,3	22	45	10,7	9,5	7				

Drop centre rims according to DIN 7827 for Implement-, MPT- and Sand tyres

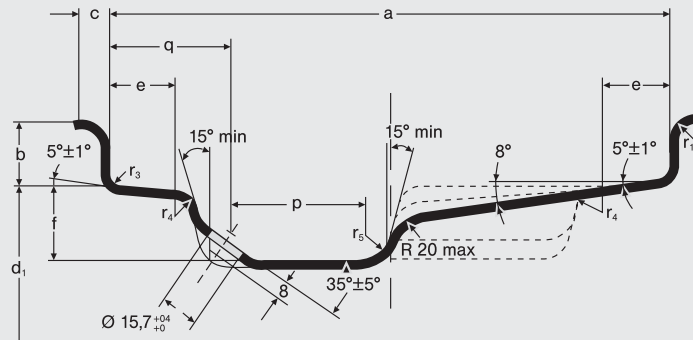

Rim size	d ₁	d ₂	U ± 2,4	a ± 2,4	b		c		e min.	f min.	p min.	q max.	r ₁	r ₂ max.	r ₃ max.	r ₄ max.
					Nom. value	Perm. value	Nom. value	Perm. value								
9 x 18	462,0	460,82	1447,1	228,6	25,4	+1,2 -0,4	12	+4 0	27	31	55	60	11	6,4	19	10
9 x 20	512,8	511,42	1606,7	228,6	25,4	+1,2 -0,4	12	+4 0	27	31	55	60	11	6,4	19	10
11 x 16	405,6	404,27	1270,0	279,4	25,4	+1,2 -0,4	12	+4 0	27	31	55	60	11	6,4	19	10
11 x 18	462,0	460,82	1447,1	279,4	25,4	+1,2 -0,4	12	+4 0	31,8	31	61	65	11	6,4	19	10
11 x 20	512,8	511,42	1606,7	279,4	25,4	+1,2 -0,4	12	+4 0	31,8	31	61	65	11	6,4	19	10
13.00 x 17	436,6	435,22	1367,3	330,2	19,0	±1,0	12	+5,5 0	30	31	61	65	11	6,4	19	10
16.00 x 17	436,6	435,22	1367,3	406,4 ±4,7	19,0	±1,0	12	+5,5 0	30	31	61	65	11	6,4	19	10
13 x 20	512,8	511,42	1606,7	330,2	25,4	+1,2 -0,4	12	+5,5 0	31,8	31	90	65	12	8	19	20
14 x 20	512,8	511,42	1606,7	355,6	25,4	+1,2 -0,4	12	+5,5 0	31,8	31	90	65	12	8	19	20
17 x 20	512,8	511,42	1606,7	431,8	25,4	+1,2 -0,4	12	+5,5 0	31,8	31	90	65	12	8	19	20

Measured with 16 mm ball.

Recommended minimum dual spacing for twin tyres

Radial	Tyre size		Correct rim		Min. centre clearance a	
		Crossply/CSE			1)	2)
		3.00-4	2.10	-4	98	94
		4.00-4	2.50	C-4	128	124
		4.00-8	3.00	D-8	134	130
5.00 R 8		5.00-8	3.00	D-8	158	152
6.00 R 9		6.00-9	4.00	E-9	192	184
6.50 R 10		6.50-10	5.00	F-10	212	204
			5.50	F-10	218	210
		7.50-10	5.50	F-10	248	238
7.00 R 12		7.00-12	5.00	S-12	230	222
		21 x 4	3.11	F-13	146	140
		22 x 4½	3.11	F-13	158	152
			3.75	P-13	166	160
		23 x 5	3.75	P-13	186	178
		25 x 6	3.75	P-13	204	196
7.00 R 15		7.00-15	5.5	-15	236	228
7.50 R 15		7.50-15	6.0	-15	254	244
			6.5	-15	260	250
8.25 R 15		8.25-15	6.5	-15	280	270
		10.00-15	7.5	-15	330	316
125/75 R 8		15 x 4½-8 (125/75-8)	3.00	D-8	138	138
			3¼	I-8	141	141
150/75 R 8		16 x 6-8 (150/75-8)	4.33	R-8	175	175
180/70 R 8		18 x 7-8 (180/70-8)	4.33	R-8	199	199
		21 x 8-9 (200/75-9)	6.00	E-9	230	230
225/75 R 10		23 x 9-10 (225/75-10)	6.50	F-10	259	259
250/75 R 12		27 x 10-12 (250/75-12)	8.00	G-12	294	294
		200-15 (250/70-15)	6.5	-15	236	236
225/75 R 15		28 x 9-15 (225/75-15)	7.0	-15	248	248
250/70 R 15		250-15 (250/70-15)	7.0	-15	282	282
			7.5	-15	288	288
315/70 R 15		300-15 (315/70-15)	8.0	-15	345	345
		355/65-15	9.75	-15	407	407

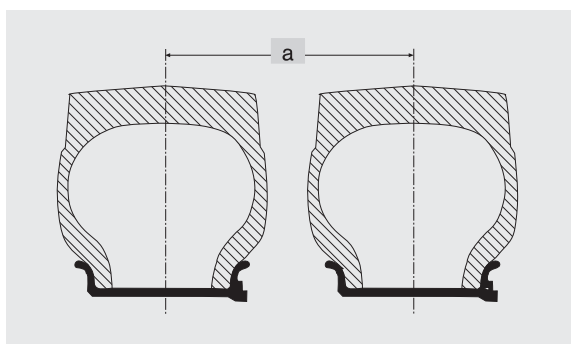

Tyre size (Radial/Crossply/CSE)	Correct rim		Min. centre clearance a	
			1)	2)
8.25-20	6.5	-20	282	269
9.00-20	7.0	-20	307	297
10.00-20	7.5	-20	330	316
10.00 R 20	7.5	-20	333	319
11.00-20	8.0	-20	348	335
12.00-20	8.0	-20	368	352
	8.5	-20	376	360
12.00 R 20	8.0	-20	371	355
	8.5	-20	379	363
12.00-20/10.0 SOLID	10.0	-20	347	-
12.00-24	8.5	-24	376	360
12.00-24 SOLID	10.0	-24	347	-
14.00-24	10.0	-24	450	-
315/55 R 16 MPT	10 x 16		368	353
	11 x 16		380	364
7.5-18 MPT	5.5 F x 18		250	240
10.5-18 MPT	9 x 18		321	308
12.5-18 MPT	11 x 18		384	368
10.5-20 MPT	9 x 20		318	304
10.5 R 20 MPT	9 x 20		318	304
275/80 R 20 MPT	9 x 20		318	304
12.5-20 MPT	11 x 20		384	368
12.5 R 20 MPT	11-20 SDC		384	368
335/80 R 20 MPT	11-20 SDC		384	368
14.5-20 MPT	11 x 20		422	405
14.5 R 20 MPT	11-20 SDC		422	405
365/80 R 20 MPT	11 x 20		456	437
	11 x 20 SDC		456	437
405/70-20 MPT	11 x 20		483	463
405/70 R 20 MPT	13 x 20		510	488

1) On fork lifts and other vehicles for max. speeds of 16 mph (25 km/h).

2) On other vehicles at speeds in excess of 16 mph (25 km/h).

Rims for press-on bands acc. to DIN 7845 resp. ETRTO

1. Cylindrical rims "z"

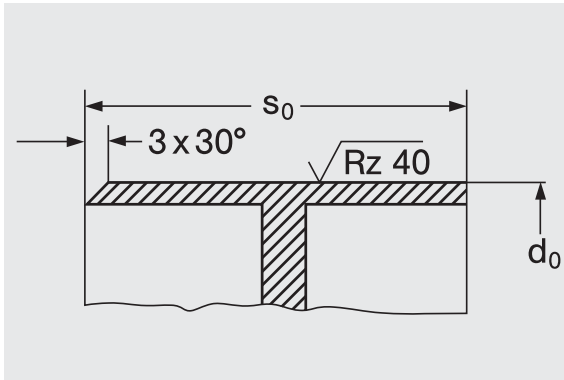

Rim width $s_0 > 1.04 \times \text{tyre width}$
Rim diameter d_0 see tyre size

2. Tapered centre-split rims "km"

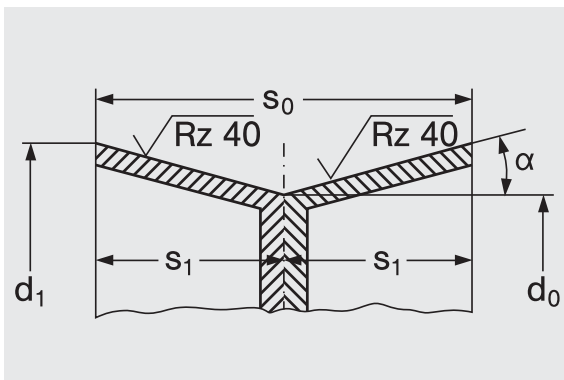

km 15: tyre width up to 90 mm
($\alpha = 15^\circ$)
km 8: tyre width 91 up to 125 mm
($\alpha = 8^\circ$)
km 10: special sizes ($\alpha = 10^\circ$)
Rim width $s_0 > 1.04 \times \text{tyre width}$
Rim width $s_1 = 0.5 \times \text{rim width } s_0$
Rim diameter d_0 see tyre size
Rim diameter $d_1 = d_0 + (s_0 \times \text{tg } \alpha)$

3. Tapered offset-split rims "ks"

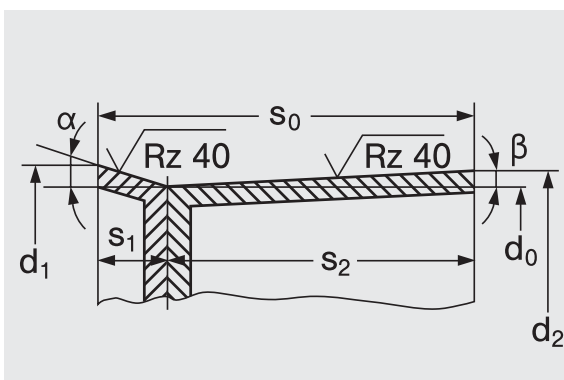

ks 15/6: tyre width 126 up to 180 mm
($\alpha = 15^\circ, \beta = 6^\circ$)
ks 15/8: tyre width over 180 mm
($\alpha = 15^\circ, \beta = 8^\circ$)
Rim width $s_0 > 1.04 \times \text{tyre size}$
Rim width $s_1 = 0.302 \times \text{tyre size}$
Rim width $s_2 = 0.738 \times \text{tyre size}$
Rim diameter d_0 see tyre size
Rim diameter $d_1 = d_0 + (2 \times s_2 \times \text{tg } \alpha)$
Rim diameter $d_2 = d_0 + (2 \times s_2 \times \text{tg } \beta)$

4. Rim tolerances

Rim version	Rim diameter tolerance for tyres with	
	designation in mm	designation in inches
cylindrical	h 11	+ 0,005" (+ 0,13 mm)
tapered	js 12	js 12

Round the rim widths up to whole mm.

The rims for steel wire reinforced press-on bands must always be at least 4% wider than the nominal width of the press-on bands. Rims which are too narrow will cut in to the base of the steel wire reinforced press-on bands and destroy them.

Rim diameter mm		Tolerance mm	
über	bis	h11	js 12
50	80	- 0,190	± 0,150
80	120	- 0,220	± 0,175
120	180	- 0,250	± 0,200
180	250	- 0,290	± 0,230
250	315	- 0,320	± 0,260
315	400	- 0,360	± 0,285
400	500	- 0,400	± 0,315
500	630	- 0,430	-
630	800	- 0,470	-

If two solid press-on bands are pressed-on to a single rim, the rim width must be dimensioned the same as for two single rims.

Rims for press-on bands (metric sizes) with cylindrical or tapered base design acc. to DIN 7845 resp. ETRTO

Tyre size	Base angle (°)		Rim dimensions (mm)					
	α	β	d_0	Diameter		s_0 2)	Width	
				d_1 1)	d_2 1)	min.	s_1 2)	s_2 2)
						min.	min.	min.
105/ 45- 65			65			67		
125/ 50- 75	15		75	88,9		52	26	
150/ 38-100	15		100	110,7		40	20	
150/ 50-100	15		100	113,9		52	26	
160/ 50-100	15		100	113,9		52	26	
160/ 75-100	15		100	120,9		78	39	
180/ 75-100	15		100	120,9		78	39	
200/ 75-100	15		100	120,9		78	39	
200/ 85-105	15		105	128,8		89	44,5	
180/100-105	8		105	119,6		104	52	
180/ 50-120	15		120	133,9		52	26	
230/ 75-120	15		120	140,9		78	39	
200/ 50-140	15		140	153,9		52	26	
250/ 75-140	15		140	160,9		78	39	
250/100-140			140			104		
250/130-140			140			136		
200/ 60-150			150			63		
265/160-160			160			167		
280/160-160	15	6	160	186	184,9	167	48,5	118,5
230/ 50-170	15		170	183,9		52	26	
250/ 60-170	15		170	186,9		63	31,5	
260/ 60-170	15		170	186,9		63	31,5	
250/ 75-170	15		170	190,9		78	39	
280/ 75-170	15		170	190,9		78	39	
250/ 80-170			170			84		
300/ 85-170	15		170	193,8		89	44,5	
310/100-170			170			104		
250/105-170			170			110		
270/105-170	8		170	185,4		110	55	
250/ 50-190	15		190	203,9		52	26	
250/ 60-190			190			63		
280/ 60-190			190			63		
310/ 75-200	15		200	220,9		78	39	
285/100-200	8		200	214,6		104	52	
310/120-200	15	6	200	219,5	218,6	125	36,5	88,5
310/140-200	15	6	200	222,5	221,9	146	42	104
300/ 90-203			203			94		

Tyre size	Rim dimensions (mm)							
	Base angle (°)		Diameter			Width		
	α	β	d_0	d_1 1)	d_2 1)	s_0 2) min.	s_1 2) min.	s_2 2) min.
300/100-203	8		203	217,6		104	52	
313/130-203	8		203	222,1		136	68	
280/ 50-220	15		220	233,9		52	26	
300/ 50-220	15		220	233,9		52	26	
310/ 60-220			220			63		
280/ 75-220	10		220	233,7		78	39	
285/ 75-220			220			78		
300/ 75-220	10		220	233,7		78	39	
310/120-220			220			125		
405/160-250	15	6	250	276,0	274,9	167	48,5	118,5
360/ 60-270			270			63		
360/ 75-270	15		270	290,9		78	39	
360/ 85-270	15		270	293,8		89	44,5	
400/ 65-305			305			68		
405/ 65-305			305			68		
400/ 75-305	15		305	325,9		78	39	
415/ 75-305			305			78		
415/ 90-305	15		305	330,2		94	47	
415/100-305	8		305	319,6		104	52	
455/100-305			305			104		
405/130-305			305			136		
425/150-305			305			156		
405/260-305			305			270		
425/260-305			305			270		
425/300-305			305			312		
450/260-305			305			270		
450/300-305			305			312		
420/ 70-340			340			73		
500/ 85-370			370			89		
520/100-370			370			104		
525/120-370			370			125		
500/125-370			370			130		
500/ 65-410	15		410	428,2		68	34	
560/100-410			410			104		
550/120-410	8		410	427,6		125	62,5	
590/120-410			410			125		
610/150-410			410			156		

Footnotes see page 91

Rims for press-on bands (metric sizes) with cylindrical or tapered base design acc. to DIN 7845 resp. ETRTO

Tyre size	Base angle (°)		Rim dimensions (mm)					
	α	β	d_0	Diameter		$s_{0\ 2)$ min.	Width $s_{1\ 2)$ min.	$s_{2\ 2)$ min.
				$d_{1\ 1)$	$d_{2\ 1)$			
550/160-410			410			167		
540/200-410			410			208		
620/200-410			410			208		
645/250-410			410			260		
645/300-410			410			312		
645/200-480			480			208		
645/250-480			480			260		
670/200-480			480			208		
750/ 75-640			640			78		
760/250-500			500			260		
920/250-670			670			260		

Rims for press-on bands (inch sizes) with cylindrical or tapered base design acc. ETRTO

Tyre size		Base angle (°)		Rim dimensions (mm)					
		α	β	d_0	Diameter		$s_{0\ 2)$ min.	Width $s_{1\ 2)$ min.	$s_{2\ 2)$ min.
					$d_{1\ 1)$	$d_{2\ 1)$			
10 x 4 x6½	254/102-165			165,1			106		
10 x 5 x6½	254/127-165			165,1			132		
10½x 5 x6½	267/127-165			165,1			132		
13 x 3½x8	330/ 89-203			203,2			93		
13 x 4½x8	330/114-203			203,2			119		
13½x 4½x8	343/114-203			203,2			119		
13 x 5 x8	330/127-203			203,2			132		
13½x 5½x8	343/140-203	15	6	203,2	225,7	225,1	146	42	104
14 x 4½x8	356/114-203			203,2			119		
16 x 5 x10½	406/127-267	15	6	266,7	287,3	286,4	132	38,5	93,5
16 x 6 x10½	406/152-267	15	6	266,7	291,4	290,2	158	46	112
16 x 7 x10½	406/178-267	15	6	266,7	295,6	294,2	185	54	131
15 x 5 x11¼	381/127-286			285,8			132		
16¼x 5 x11¼	413/127-286			285,8			132		
15 x 6 x11¼	381/152-286			285,8			158		
16¼x 6 x11¼	413/152-286			285,8			158		
16¼x 7 x11¼	413/178-286			285,8			185		

Tyre size		Rim dimensions (mm)							
		Base angle (°)		d ₀	Diameter		s ₀ 2) min.	Width	
		α	β		d ₁ 1)	d ₂ 1)		s ₁ 2) min.	s ₂ 2) min.
17 x 4½ x 12½	432/114-308			308			119		
18 x 5 x 12½	457/127-308			308			132		
18 x 6 x 12½	457/152-308			308			158		
18 x 7 x 12½	457/178-308	15	6	308	336,9	335,5	185	54	131
18 x 8 x 12½	457/203-308			308			211		
18 x 9 x 12½	457/229-308			308			238		
21 x 9 x 13	533/229-330	15	8	330,2	367,2	377,7	238	69	169
21 x 5 x 15	533/127-381			381			132		
21 x 6 x 15	533/152-381			381			158		
21 x 7 x 15	533/178-381			381			185		
21 x 8 x 15	533/203-381			381			211		
21 x 9 x 15	533/229-381	15	8	381	425,7	424,4	238	83,5	154,5
22 x 6 x 16	559/152-406			406,4			158		
22 x 8 x 16	559/203-406			406,4			211		
22 x 9 x 16	559/229-406			406,4			238		
22 x 10 x 16	559/254-406			406,4			264		
22 x 12 x 16	559/305-406			406,4			317		
22 x 14 x 16	559/356-406			406,4			370		
22 x 16 x 16	559/406-406			406,4			422		
28 x 10 x 22	711/254-559			558,8			264		
28 x 12 x 22	711/305-559			558,8			317		
28 x 16 x 22	711/406-559			558,8			422		

1) The diameters d₁ and d₂ refer to given rim widths s₁ and s₂.

If these measurements are exceeded, d₁ and d₂ must be enlarged according to the angles α and β.

2) Elastic steelbandes tyres: s₀ = width of tyre.

Valve accessories according to DIN 7757

An absolutely airtight fit of the valve insert is guaranteed only when the valve cap is screwed on firmly and this is also indispensable as a protection against dirt. Dust caps (without seal) only provide a little protection.

In many cases a valve extension is essential in order to be able to check the tyre pressure during use without having to specially examine the wheels or clean them off and without the need of special extensions for using the tyre pressure measuring and inflating equipment.

Ask your valve manufacturer about valve extensions.

Valve insert 20: For valves with normal bore

Valves for tubes

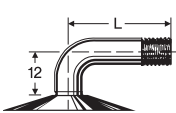
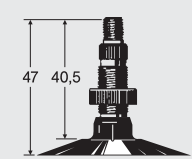
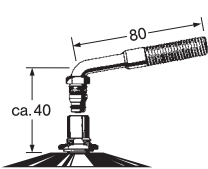
	Valve designation			Valve hole dia.	L
	DIN	ETRTO	TRA		
 <p>DIN 7774</p>	38 G 11.5 38 G 16	V 2-01-1 V 2-01-2	TR 13 TR 15	11,5 16,0	35 35
 <p>DIN 7777</p>	28 G-90 38 G-90 41.5 G-70	V 6-01-1 V 1-08-2 V6-02-1	- - -	- - -	28 38
 <p>DIN 7773</p>	47 GW	V 4-02-1 insert for water filling V 4-01-1 Valve base	TR 218 A	16	-
 <p>DIN 7786</p>	Angled valve 80 GD 80	V 5-04-01 Valve body - Valve base	TR-J650 Valve body SP 4000 Valve base	20,5	

Rubber valves for tubeless fitting

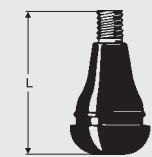
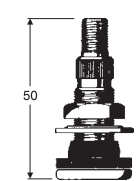
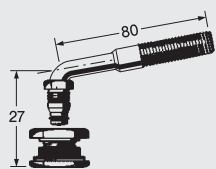
	Valve description			Valve hole dia.	L
	DIN	ETRTO	TRA		
 <p>DIN 7780</p>	- 43 GS 11.5 49 GS 11.5 43 GS 16.5	V 2-03-9 V 2-03-1 V 2-03-2 V 2-03-3	- TR 413 TR 414 TR 415	8,8 11,3 11,3 15,7	59,0 42,5 48,5 42,5
 <p>DIN 7826</p>	50 MSW	V 4-02-1 insert for water filling V 5-01-1 Valve base	TR 618 A	16	
 <p>DIN 7786</p>	Winkel- ventil 80 DS 80	V 5-04-1 Valve body V 5-10-1 Valve base	TR-J650 Valve body TR-SP 2 Valve base	20,5	

Screw-on angled valves with turning plate, according to DIN 7775/2

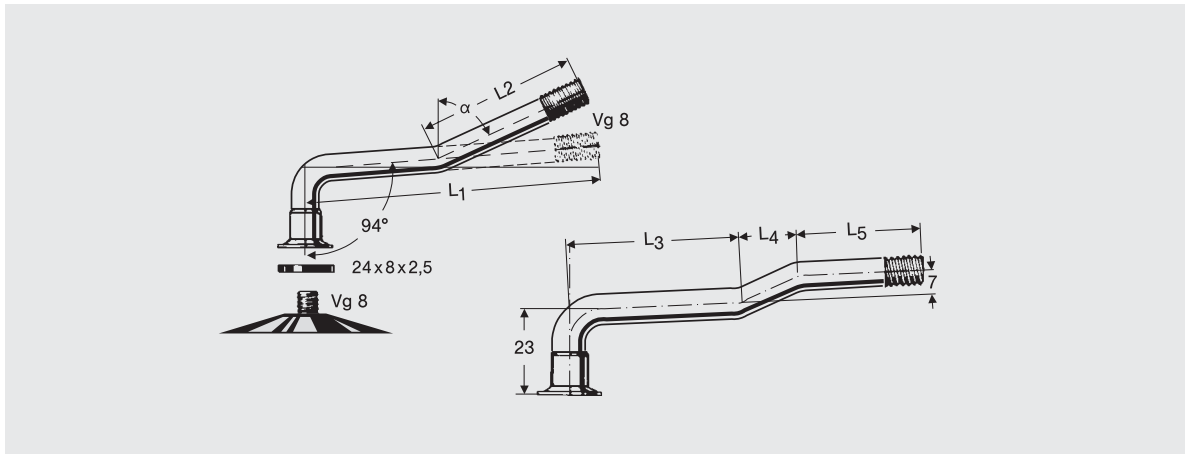

Valve description		Shaft length						Alpha in degrees
DIN	similar ETRTO*)	L ₁ ± 3	L ₂	L ₃	L ₄	L ₅		
single angled								
50 D	V3-02-5	50					90	
60 D	V3-02-19	60					94	
75 D	V3-02-27	75					94	
85 D	V3-02-8	90					94	
105 D	V3-02-26	105					94	
double angled								
(43 D-60)**)	V3-02-2	43					120	
75 D-74	V3-04-22	75	47				74	
95 D-74	V3-04-23	95	47				74	
105 D-74	V3-04-24	105	47	-	-	-	74	
115 D-74	V3-04-20	115	47				74	
127 D-74	V3-04-25	127	47				74	
140 D-64	V3-04-21	140	57				64	
triple angled								
95 D-Z	V3-06-2	95		40	13	40		
105 D-Z	V3-06-14	105		50	13	40		
115 D-Z	V3-06-15	115		60	13	40		
127 D-Z	V3-06-16	127		62	13	50		
140 D-Z	V3-06-17	140		75	13	50		

*) see ETRTO Standards manual

***) based on DIN = ()

Regrooving of CSE-tyres

SC 10



SC 15



SC 20



When the original tread pattern is worn down, the tyre has reached approximately half its useful service life. It can remain in service and where necessary be regrooved, so that it continues to provide good road holding on wet dirty surfaces. In order to maintain the remouldability of the tyre, the wear and regrooving limits should not be exceeded. Patterns SC 15/SC 10 may be regrooved down to the upper edge of the 60 Joule ridge (tyre shoulder).

Regrooving should only be carried out in stages.

Only when the tyre has once again been worn down should the second stage apply, in which the remaining tread is regrooved.

Please note! Industrial pneumatic tyres must not be regrooved.

The CSE pattern may be regrooved down to the upper edge of the 60 Joule ridge.

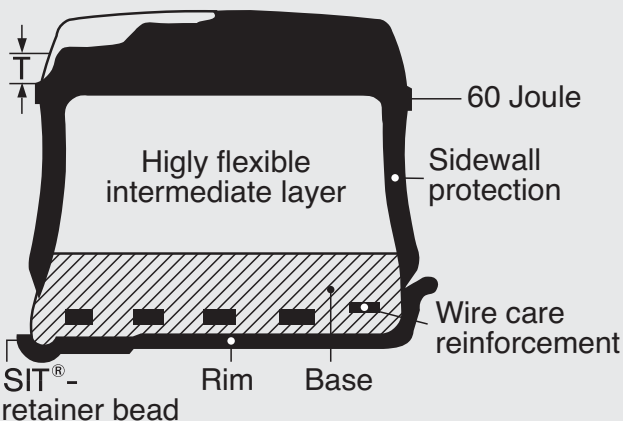

The following regrooving pattern is recommended:

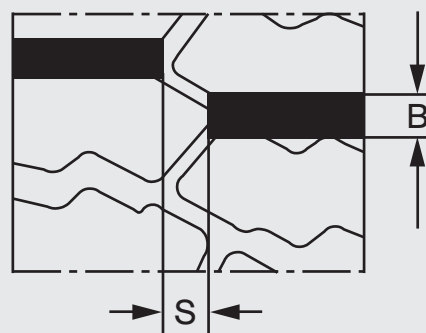

Regrooving of CSE tyres

Tyre Size	Tread	Regrooving dimensions		
		Depth T mm	Width B mm	Centre rib S mm
3.00 -4	MIL	10	6	15
4.00 -4	SC 10	10	6	15
15 x 4½-8	SC 10	10	8	20
	SC 11	15	5	-
125/75 -8	SC 15	8	12	15
	SC 20	10	12	15
4.00 -8	SC 10	10	8	15
5.00 -8	SC 10	12	8	20
16 x 6 -8	SC 10	7	10	25
150/75 -8	SC 15	14	12	25
	SC 20	15	12	25
18 x 7 -8	SC 10	13	10	25
180/70 -8	SC 15	17	12	25
	SC 20	22	17	25
140/55 -9	SC 11	-	-	-
	SC 15	17	12	15
	SC 20	17	12	15
6.00 -9	SC 10	14	10	25
	SC 15	23	10	25
21 x 8 -9	SC 10	16	12	30
200/75 -9	SC 15	20	15	30
	SC 20	20	15	30
6.50 -10	SC 10	16	10	25
	SC 15	24	12	25
	SC 20	23	12	25
7.50 -10	SC 10	18	12	30
200/50 -10	SC 10	14	12	35
	SC 20	13	12	35
180/60 -10	SC 15	14	12	35
23 x 9-10	SC 10	18	12	35
225/75 -10	SC 15	24	15	35
	SC 20	25	15	35
7.00 -12	SC 10	16	12	30
	SC 15	26	15	30
	SC 20	28	15	30
23 x 10-12	SC 10	14	15	40
250/60-12	SC 20	14	15	40

Tyre Size	Tread	Nachschneidemaße		
		Depth T mm	Width B mm	Centre rib S mm
27 x 10-12	SC 10	18	20	40
215/45-12	SC 20	14	20	40
250/75 -12	SC 15	25	20	40
	SC 20	27	20	40
22 x 4½	SC 10	12	8	20
23 x 5	SC 10	14	10	25
25 x 6	SC 10	16	10	25
7.00 -15	SC 10	16	12	30
	SC 15	30	12	30
7.50 -15	SC 10	18	15	35
	SC 15	32	15	35
8.25 -15	SC 15	20	12	35
	SC 15	37	18	35
	SC 20	34	18	35
200 -15	SC 10	16	15	35
28 x 9 -15	SC 10	15	15	40
	SC 10	15	15	40
225/75 -15	SC 15	20	18	40
	SC 20	23	18	40
355/45 -15	SC 15	17	25	50
250 -15	SC 10	16	15	40
250/70 -15	SC 15	37	18	40
	SC 20	32	18	40
300 -15	SC 10	20	15	45
315/70 -15	SC 15	30	20	45
	SC 20	33	20	45
355/65 -15	SC 10	23	20	50
	SC 15	30	25	50
	SC 20	30	25	50
8.25 -20	SC 15	21	15	35
10.00 -20	SC 15	25	18	45
12.00 -20	SC 15	28	18	45
	SC 15	28	18	50
14.00 -24	SC 15	32	20	55

Fitting and removal of CSE tyres

Radial and axial pre-tensioning in the base of line CSE press on bands ensure a firm fit on pneumatic rims.

Care must be taken to select the correct rim: the clear rim must correspond to the width of the tyre base.

Some sizes of the “S” base type for off-centre split rims are also available for standard centre-split rims (see pages 34, 36, 38 and 40, Index 2).

The CSE tyre with the **SIT**[®] type base is designed to suit the contours and sizes of the Lemmerz offset-split rim. The specially designed base with its retaining bead makes it possible to fit the tyre on to the basic rim without the need for the detachable rim elements.

Fitting on to an offset-split rim

Press tyre on with a claw or plate press

Fitting on to a centre-split rim

Push tyre manually on to one half of the rim, then ease up the other half. Then press together the two rim parts with a hydraulic press and screw together.

Instructions for fitting and removing CSE press-on bands using a claw or plate press

Preparation

- Clean the rim and remove any burrs which may have resulted from running into obstacles. The front edge in particular should be chamfered.
- Coat the contact areas of the rim and tyre with the recommended fabricant.
- Place rim on press table using the appropriate support ring.

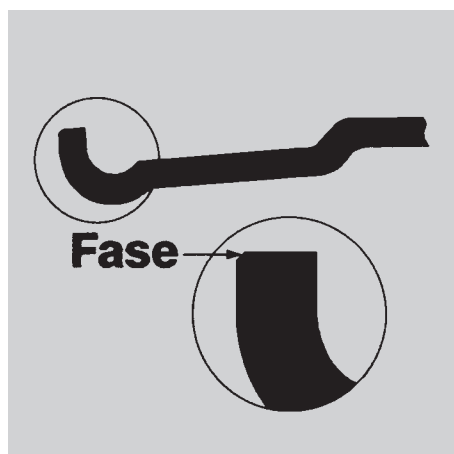

Use a fitting aid

- a lubricant which later evaporates is an aid to fitting.

Recommended: press-on bands lubricant, article no. 5930388 produced by Tip Top Stahlgruber, Postbox 801822, 81675 Munich.

The filling paste normally used for pneumatic tyres should not be applied as a firm sealing of the tyre cannot then be guaranteed.

Fitting and removal using an SE Unimont

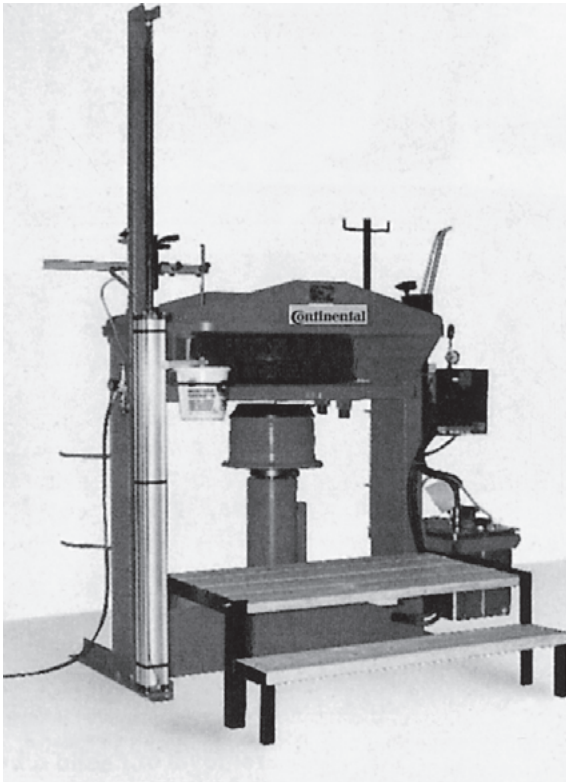

The SE Unimont has been designed specially for the fitting and removal of CSE tyres and Elastic press-on bands. A swivelling, pneumatic lifting device enables one-man operating of the SE Unimont.

In principle it works like a 4-claw press, but the claws and the pressure ring have been replaced by a single ring.

Information:

Tip Top Stahlgruber
P.O.Box 8018 22
81675 Munich
Phone +49 89/4 55 14 19

Fitting and removal using a 4-claw press

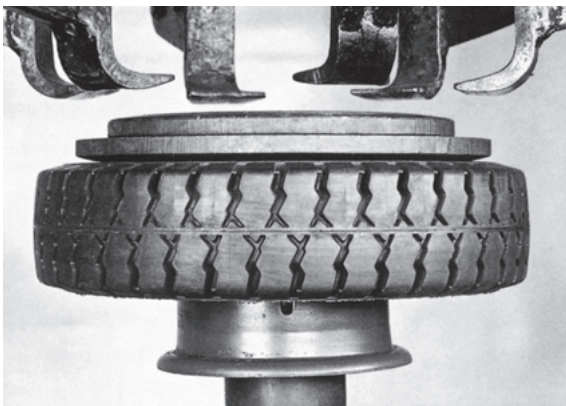

4-claw press

Basic tools required for fitting and removal of press-on bands using a 4-claw press

- Rim support rings or plates corresponding in size to the type of press used, on order to support the rim:
 - on the fixed flange side when pressing on (B)
 - on the open side when pressing of (C)

One ring or plate is needed for each rim diameter.

- An additional spacer tube (D) is needed if the stroke length of the press is not sufficient (small tyres).
- Tyre pressure sleeve (A) to protect the side-walls of the tyre from being damaged by the claws when being pressed on and of.
- Hammer and sledge.
- Tyre laver.

Fitting using the 4-claw press

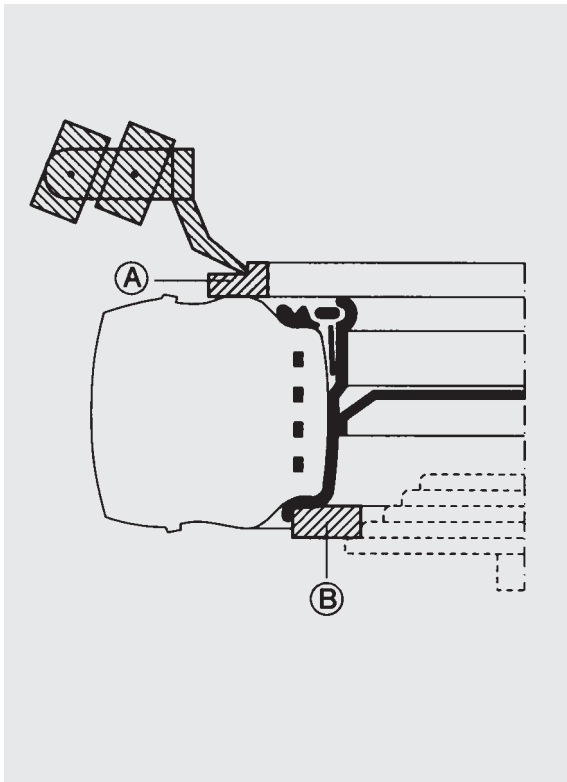

Using basic tools to fit press-on bands on a claw press

- Place tyre level on rim. Use tapered ring if necessary for centring.
- Position pressure sleeve on tyre.
- Lower claws and press tyre on the rim until it contacts the fixed rim flange.
- Position taper ring and hammer it into place using hammer and broadnosed chisel.
- Place side ring in position.
- Position locking ring and hammer it into place (together with the side ring).
- Invert wheel with tyre on the press table and press all loose rings further into place in order to stop rattling noise and additional wear during operation.

Removal using the 4-claw press

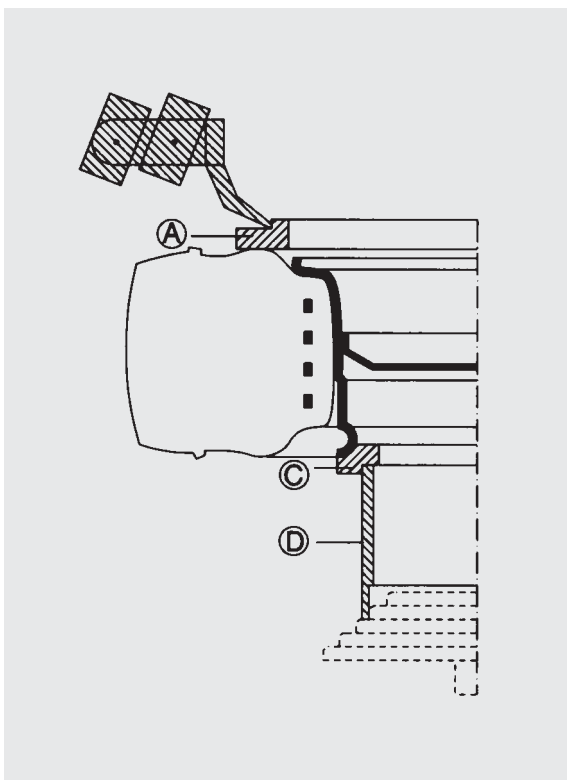

Removal

- Place the appropriate support ring on the press table and position wheel with open side facing upward.
- Compress tyre using the tyre pressure sleeve.
- Lift off the taper and locking rings using tyre levers.
- Invert the wheel on the press table.
- Support the rim on the press table using the pressure ring or pressure tube provided for the open side.
- Use the tyre pressure ring to press the tyre off the rim.

Fitting and removal using a plate press

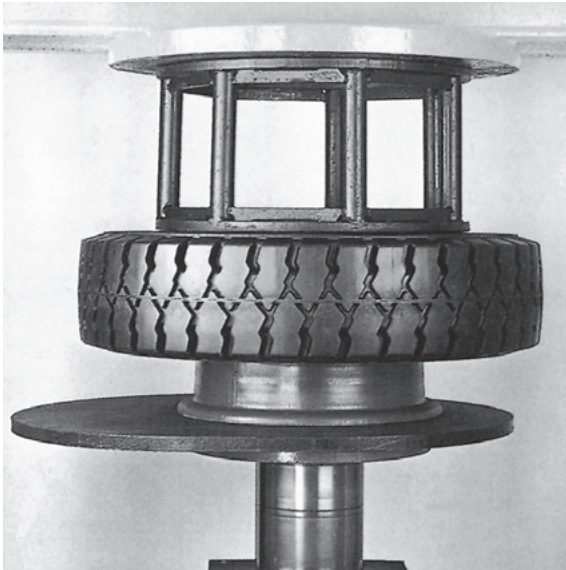

Plate press

Basic tools required for fitting and removal of press-on bands using a plate press

- Rim support rings corresponding in size to the rim diameter to support the rim on the fixed flange size while the tyre is being pressed on ②.
- Rim support tubes as in size to the rim diameter to support the rim on the open side while the tyre is being pressed off ③.
- Pressure cages ① for pressing tyres on and off. Each pressure cage can be reversed and thus used for two rim diameters.

Plate press

- 100-150t pressure for all CSE tyres, even those over 15" diameter and for pressing Elastic tyres on and off.

Fitting using the plate press

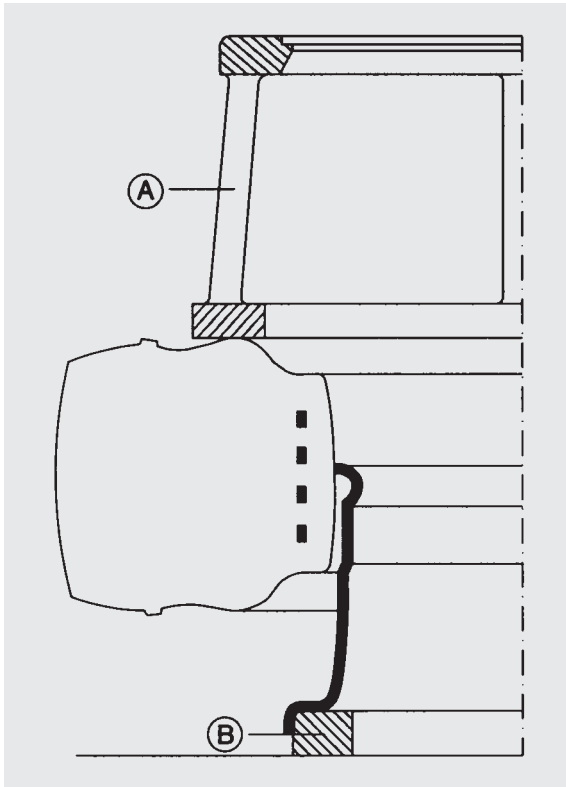

Using basic tools to fit tyres on a plate press

- Place tyre level on the rim. Use tapered ring if necessary for centring.
- Position pressure cage on tyre and press tyre down until it contacts the fixed rim flange.
- Position taper ring and hammer it into place using hammer and broad-nosed chisel.
- Place side ring in position.
- Position locking ring and hammer it into place (together with the side ring).
- Invert wheel with tyre on the press table and press all loose rings further into place in order to stop rattling noise and additional wear during operation.

Removal using the plate press

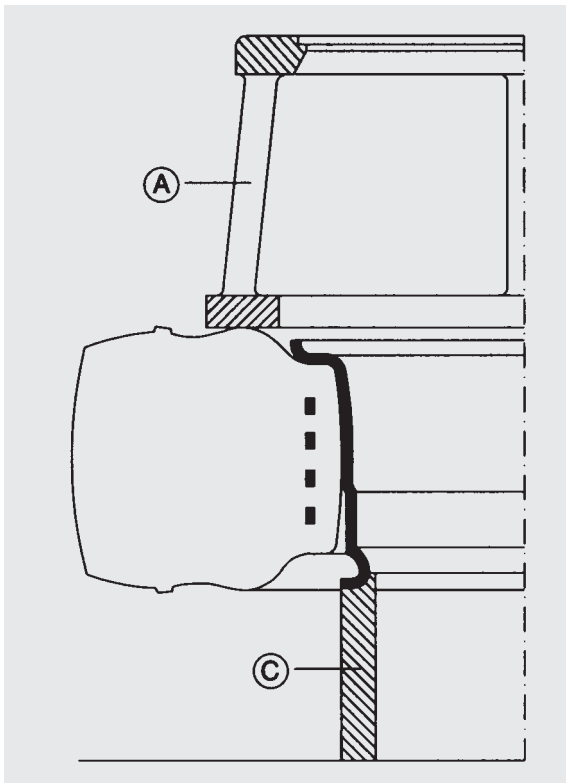

Removal

- Place the appropriate support ring on the press table and position wheel with open side facing upward.
- Compress tyre using the tyre pressure cage.
- Force off the taper and locking rings using tyre levers.
- Invert the wheel on the press table.
- Support the rim on the press table using the pressure ring or pressure tube provided for the open side.
- Use the tyre pressure cage to press the tyre off the rim.

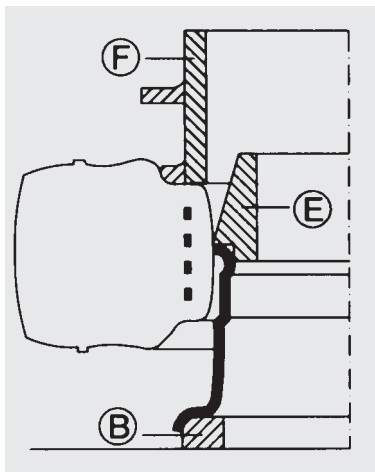

Pressing a tyre on

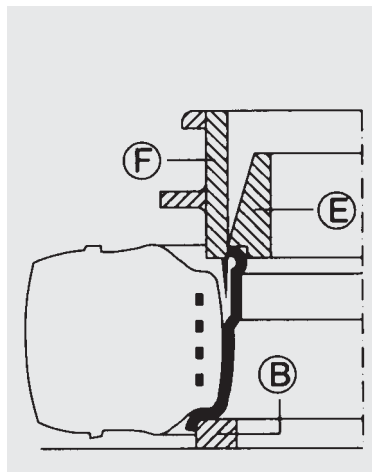
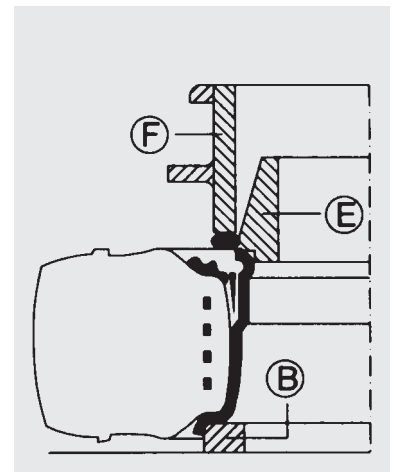
Inserting the
the taper ringInserting
locking ring

Additional tools to further facilitate tyre fitting using a 4-claw or plate press

For safety reasons only one-piece locking rings are used nowadays, making manual fitting more difficult. With the aid of the appropriate tools, i.e. a tapered ring (E) and pressure ring (F) fitting the taper ring and the locking ring can be carried out simply and precisely using both types of press. One set of rings is necessary for each rim diameter.

The tapered ring (E) must fit the open side of the rim exactly. Its function are:

- to centre the tyre while it is being pressed on to the rim.
- to centre the tyre while the taper ring is being pressed into position.
- to act as an expansion sleeve while the locking ring is being pressed into position.

The inner diameter of the pressure ring (F) must correspond to the outer diameter of the tapered ring so that it can slide over the latter. It is used when:

- the tyre is being pressed on.
- the taper ring is being pressed into position.
- the locking ring is being pressed into position.

The pressure ring (F) can replace the pressure rings on the 4-claw press and the pressure cage on the plate press.

Montage mit Zusatzwerkzeugen auf der Klauen- und Plattenpresse.

- Place tapered ring on rim.
- Place tyre on tapered ring.
- Position pressure ring and press tyre over the tapered ring on to the rim until it contacts the rim flange.
- Place taper ring over the tapered ring and press it into place with the pressure ring.
- Place side ring into position.
- Place locking ring into position over the tapered ring and press it into place (together with the side ring) using the pressure ring.

Additional tool can be obtained from the press manufacturers. Technical drawings are available on request from our CENTRAL CUSTOMER SERVICE DEPARTMENT if customers wish to make their own tools.

Set of removal rings



Programme:

No.	Rim	Tyre
1	3.00 D-8 4.00-8 5.00-8 15 x 4½-8	4.00-8
2	4.33 R-8	16 x 6-8 18 x 7-8
3	4.00 E-9 6.00 E-9	6.00-9 21 x 8-9

No.	Rim	Tyre
4	5.00 F-10 6.00 F-10	6.50-10 23 x 9-10 200/50-10
5	5.00 S-12	7.00-12
6	8.00 G-12	23x10-12 27x10-12
7	3.11 F-13 3.75 P-13	22 x 4½ 23 x 5 25 x 6

No.	Rim	Tyre
8	5.5-15 6.5-15	7.00-15 7.50-15 8.25-15 200-15 28x9-15
	7.0-15	250x15 300-15 355/65-15
	8.0-15 9.75-15	300-15 355/65-15
9	6.5-20 8.0-20 8.5-20	8.25-20 10.00-20 12.00-20

Fitting instructions



(Please check our fitting instructions in 17 languages)

Functioning of the CSEasy

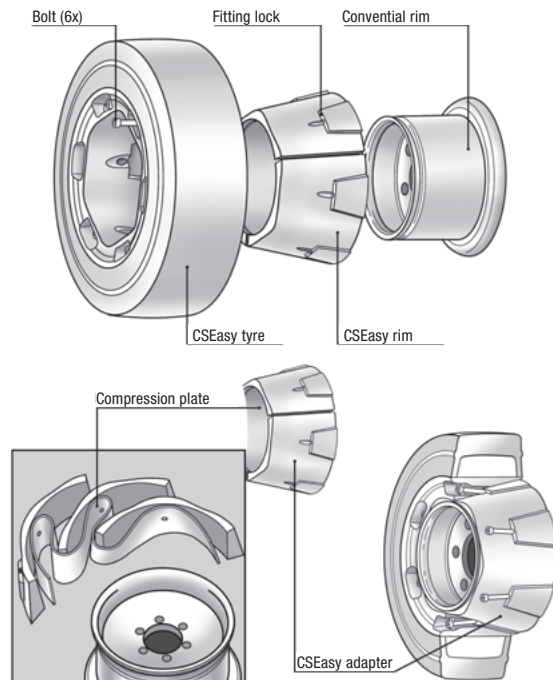

The inner adapter consists of three segments and a rubber layer (compression plate) which are pre-fitted.

If an old SE tyre is fitted, the standard dismantling process for SE tyres should always be followed.

CSEasy fitting instructions

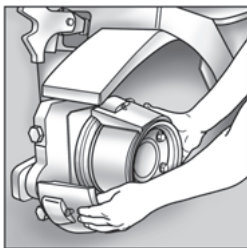

If a CSEasy tyre is already fitted to the vehicle, dismantling and fitting can be carried out on the vehicle if the fixed rim flange is on the inside.

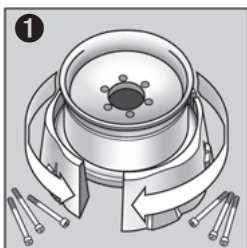

Place the CSEasy adapter around the rim. Raise the positioned rim slightly so that the adapter can be slotted into the SIT groove. Avoid creases forming in the compression plate while doing this. Do not use any tools at this stage.

Please note:

Different fastenings are available for the various tyre sizes!

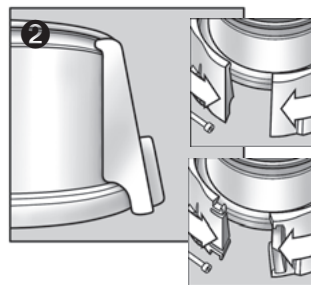

Ensure the vehicle cannot • roll away or • tip over during fitting.

Use the correct jack to lift the vehicle. Always clean the tyre, adapter and rim before fitting. Check for damage and replace if necessary. Ensure that the working area is safe and suitable for the fitting process. Do not use grease or lubricants for fitting. do not pre-warm or pre-cool the components.

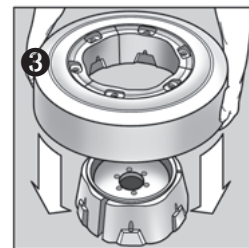

Position the CSEasy tyre to line up the rim with adapter.



If plastic elements are to be re-used, check these for damage. Do not use any plastic

elements after the expiry date printed on them. See expiry date mm/yyyy

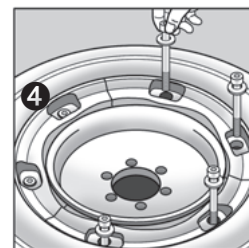

Insert all bolts in the appropriate holes by hand. Only use the material provided.

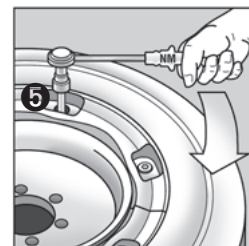

Tighten the bolts crosswise to the appropriate torque. **Subsequent fitting:** Check bolts and thread optically.

Use an adjustable torque wrench to tighten the bolts to the correct torque (see table).
The bolts should be tightened crosswise. After fifty (50) hours in operation, the bolts should be re-tightened to the correct torque.

Size	Rim	Bolt type mm	Strength	Torque Nm	Corrosions protection
5.00-8	3.00 D-8	M 8 x 75	10.9	25	Dacromet
125/75-8	3.00 D-8	M 8 x 75	10.9	25	Dacromet
150/75-8	4.33 R-8	M 10 x 110	8.8	49	Electrogalvanised
180/70-8	4.33 R-8	M 10 x 110	8.8	49	Electrogalvanised
6.00-9	4.00 E-9	M 10 x 100	8.8	49	Electrogalvanised
200/75-9	6.00 E-9	M 12 x 145	8.8	85	Electrogalvanised
225/75-10	6.50 F-10	M 12 x 160	8.8	85	Electrogalvanised
7.00-12	5.00 S-12	-	8.8	85	Electrogalvanised

CSEasy dismantling instructions

Do not use a press to dismantle the CSEasy.

If the CSEasy is to be dismantled while fitted to the vehicle:



Ensure the vehicle cannot roll away or tip over during fitting!



Ensure that the tyre does not slip off the rim when the bolts are loosened (if necessary, use assistance).

Use the correct jack to lift the vehicle.

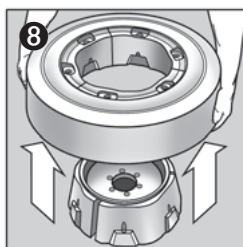

Remove the tyre from the rim.

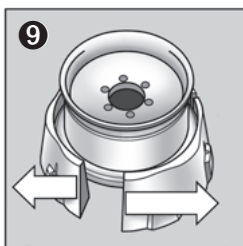

Ensure that the expiry date of the adapter is still valid.
If necessary, loosen the adapter at the ends indicated in colour.

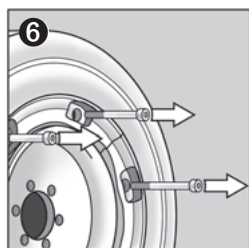

Loosen the bolts with an Allen key and remove carefully.

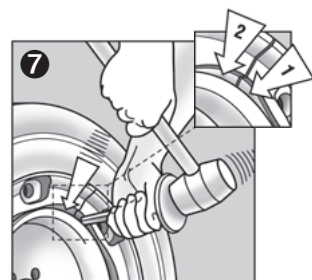

If the tyre does not come loose on its own, use a rubber mallet and an appropriate tool (e.g. drill drift or mandrel with hand guard) and tap lightly and precisely on the areas indicated in the drawing with arrows 1 and 2.

General safety advice



Do not use components for other purposes.

Ensure that no items get caught between the adapter parts.

Protect your hands and feet from injury.

Solid rubber products can be very heavy.

- When fitting tyres over 10" in size, use a lifting device.

Do not store outside.

All CSEasy CLEAN tyres are electrically non-conductive.

Fitting and removal of CSE tyres with SIT[®] type base

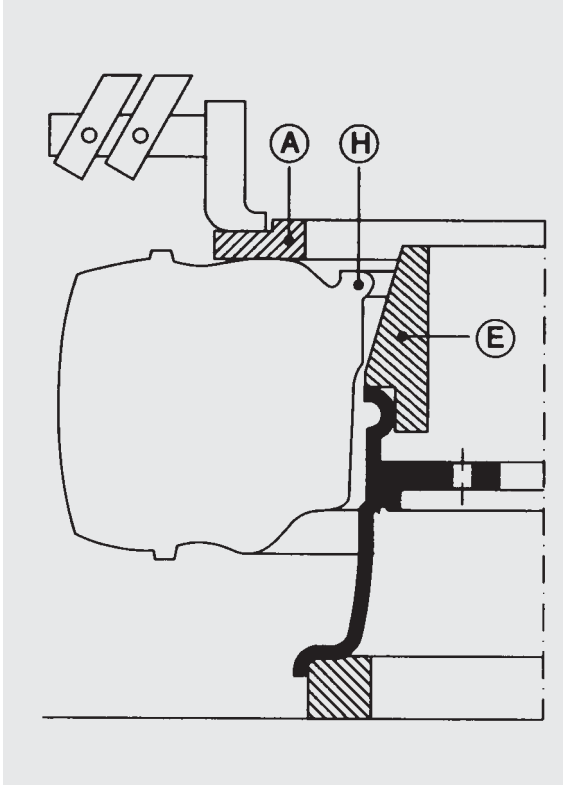

Fitting

- Clean rim and remove burrs from the edge on the open side.

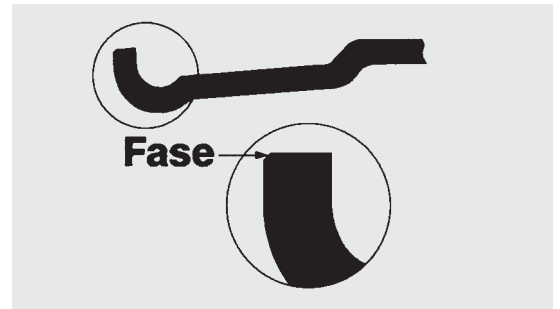

- Position tapered ring (E).
- Coat inside of tyre and contact areas of tapered ring and rim liberally with lubricant.
- Place tyre on tapered ring and press down evenly with pressure sleeve (A) until the retaining bead (E) snaps into place in the locking ring groove.

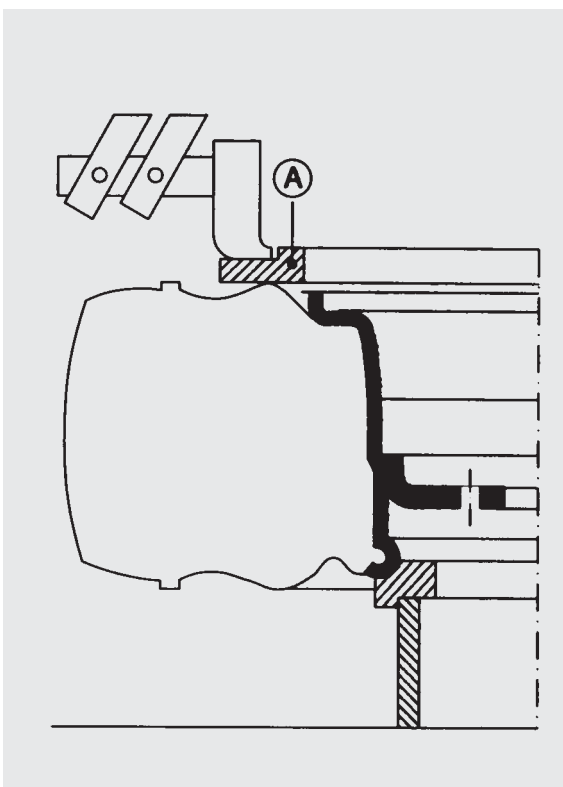

Removal of worn tyre

- Place pressure (A) on tyre and press tyre off. The retaining bead is sheared off the process.

High pressure is required when pressing the tyre off. Damage to the wheel can be avoided by supporting it on the edge of the rim, as shown in the diagram, and not on the docking disc.

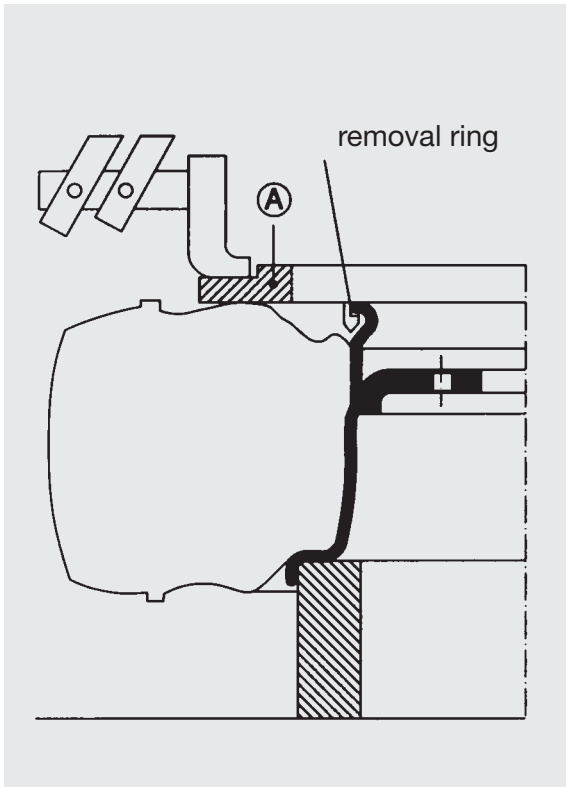

Removal of CSE-SIT tyres for subsequent re-use – a removal ring is needed

- Compress tyre from the locking side of the rim using the pressure ring (A) until the locking ring groove is exposed.
- Place removal ring in position and coat liberally with lubricant.
- Invert tyre and press off using pressure ring (A). The retaining bead then slips over the removal ring without being sheared off.
- Measurements and drawings for pressure cages pressure rings and tapered rings are available on request.

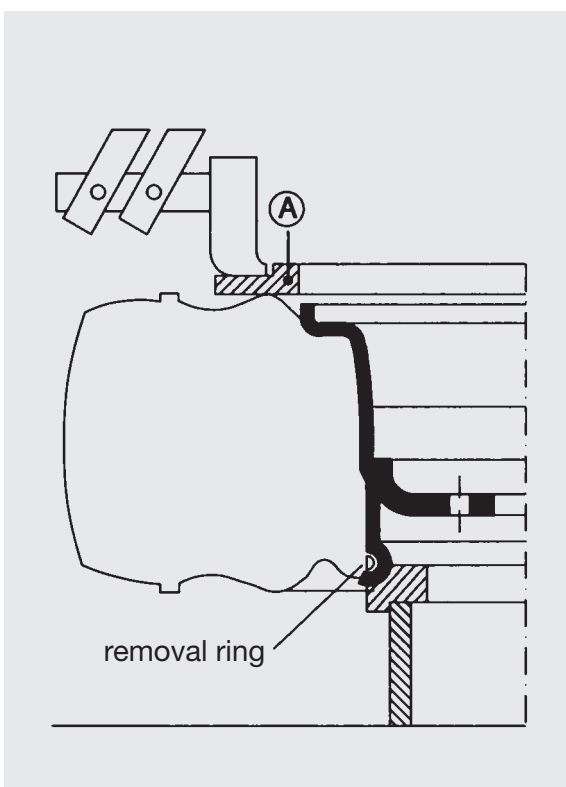

Use a fitting aid

- a lubricant which later evaporates is an aid to fitting

Recommended: press-on bands lubricant, article no. 593 0388 produced by Tip Top Stahlgruber, P.O.Box 80 18 22, 81675 Munich.

The filling paste normally used for pneumatic tyres should not be applied as a firm sealing of the tyre cannot then be guaranteed.

Fitting and removal of press-on bands with cylindrical base

Rims

Secure sealing of the tyre is only possible if the correct rim size is used:

Previously-used rims should be cleaned prior to fitting. Dents and burrs on the edges of the rim caused by running into obstacles should be removed. The tolerances for the outer diameter of the rim see as follows:

Rim outer dia. mm	Tolerance h11 (ISO/R 286) mm	Rim surface quality of tyre seal area: (smooth)
50... 80	0... -0,190	$R_t=16-32 \mu\text{m}$
80... 120	0... -0,220	$R_a=3,2-6,3 \mu\text{m}$
120... 180	0... -0,250	
180... 250	0... -0,290	
250... 315	0... -0,320	
315... 400	0... -0,360	
400... 500	0... -0,400	

If the surfaces are too rough the tyre will not slide evenly into position as it is pressed on. The rim edge should be chamfered $1/45^\circ$. Excessive chamfering, especially in the case of narrow rims, can impair the tyre's fit of the rim.

The rims must always be at least 4% wider than the normal width of the tyres. When tyres are fitted to rims that are too narrow, the base edges of the rims cut into the base of the tyre, leading to premature tyre destruction. If two tyres are to be pressed on to a single rim, the rim width must be dimensioned the same as for two single rims.

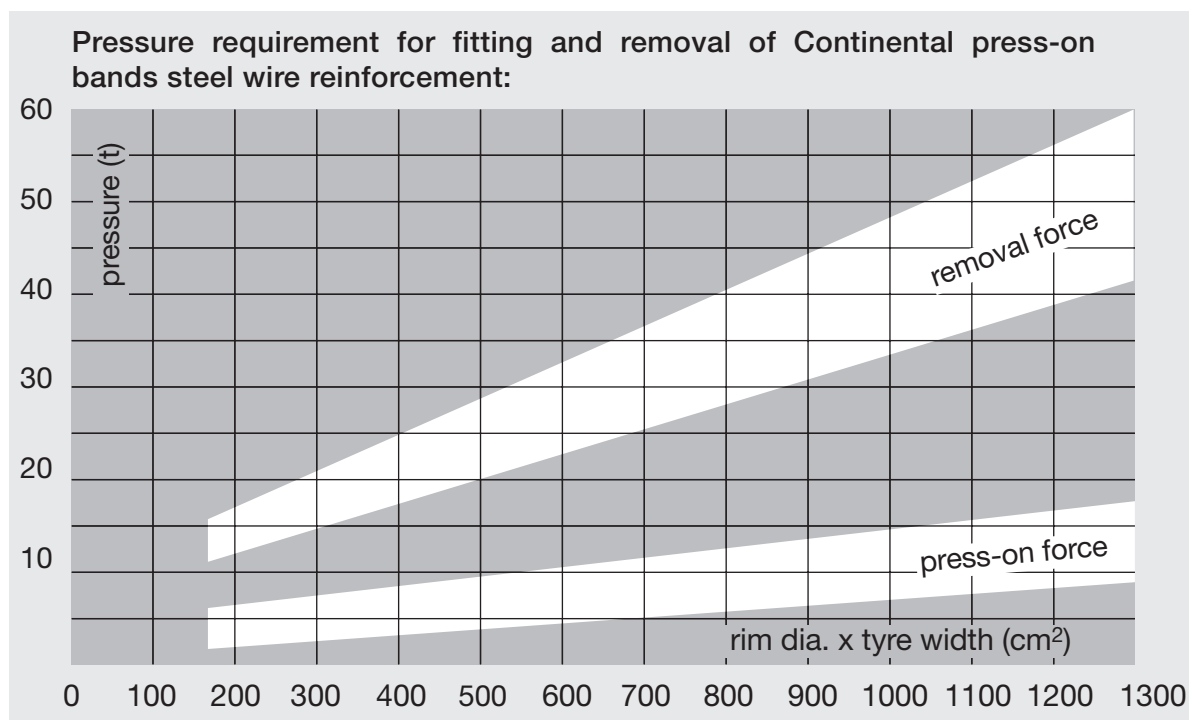

Fig. 1 Expansion ring (C)

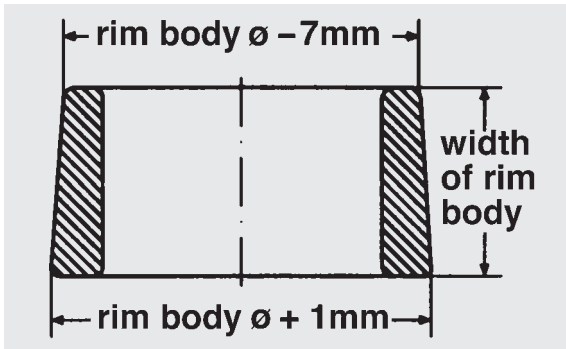

Fig 2. Pressure ring (A)

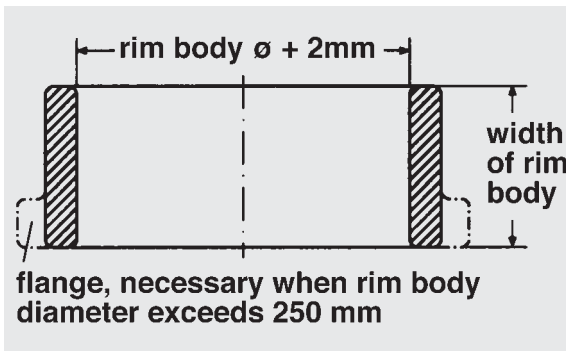
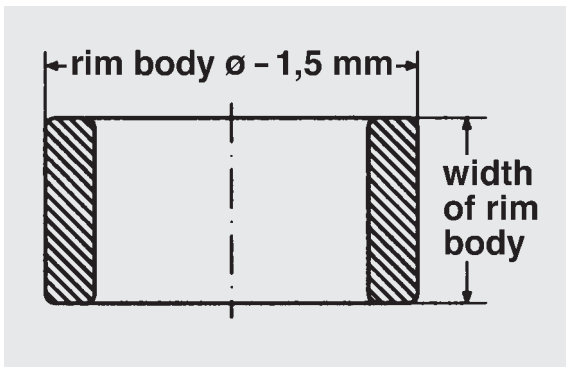

Fig 3. Support ring (E)



Tools and technical aid

The fitting and removal of press-on bands with cylindrical base is best done on a hydraulic plate press. The press must apply its force level and parallel at a pressing speed of approx. 35 mm/sec. There are special presses available for this purpose, capable of exerting a pressure of 100-200 tons.

Additional tools and technical aids are required:

For press-on bands with steel wire reinforcement (rubber base):

- Expansion ring (fig. 1), to suit the rim diameter (max. outer dia. = rim dia. + 1 mm). The ring also serves as a support when pressing off the tyres. Tyres of up to 100 mm in width can be pressed on without using an expansion ring if the rim has a chamfer of less than 30° over at least 3 mm width on the side where the tyre is to be pressed on.

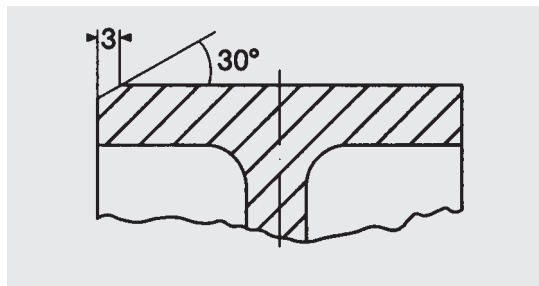

- Pressure ring (fig. 2) to suit the rim diameter (inner dia. = rim dia. + 2mm). Pressure blocks must not be used instead of this pressure ring!
- Support ring (fig. 3) to suit the rim diameter (outer dia. = rim dia. % 1,5 min). This ring is used to support the rim when pressing tyres on and off.
- Lubricant: do not use oil, grease or fitting paste for pneumatic tyres. Recommended lubricant: see page 101).

For tyres with steel base:

- Support ring (fig. 3)
- Pressure ring (fig. 2)
- Lubricant: Lightly lubricate both steel contact areas on the rim and in the tyre.

Tyre with steel wire reinforcement

Fig. 4

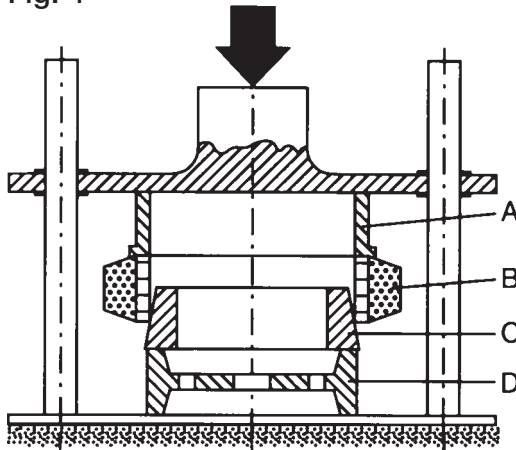

Tyre with steel base

Fig. 5

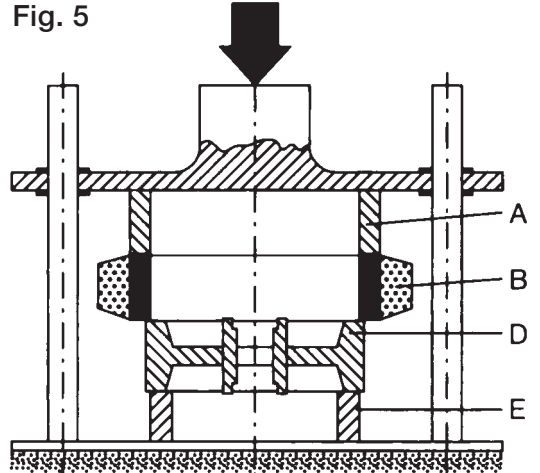

Fig. 6

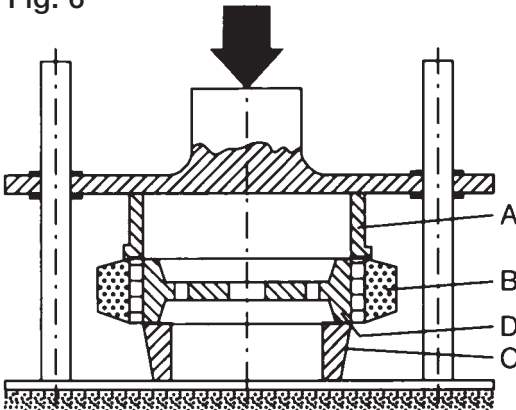
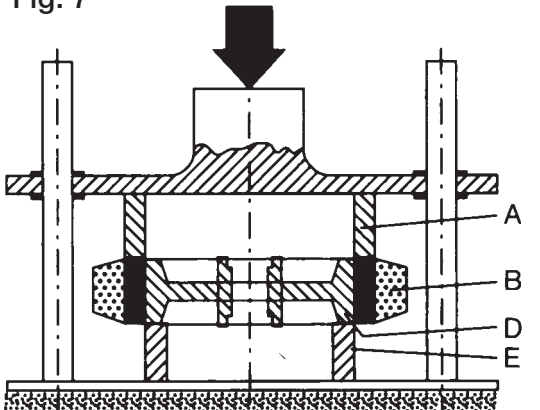
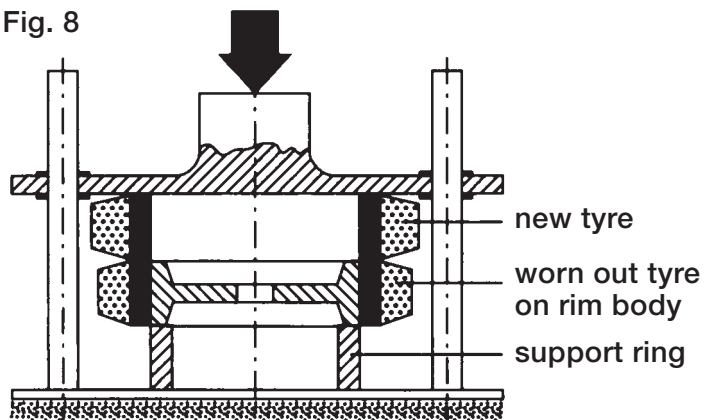

Fig. 7



- A – pressure ring
- B – Tyre
- C – Expansion ring
- D – Rim body
- E – Support ring

Fig. 8



- new tyre
- worn out tyre on rim body
- support ring

Pressing on press-on bands with steel wire reinforcement (fig. 4)

- Place rim body **D** on press table and centre expansion ring **C** on top of the rim body.
- Lubricate all contact areas (expansion rim, outer side of the rim, inner side of tyre **B** with diluted lubricant.
- Position tyre **B** on expansion ring **C**, centre pressure ring **A** on the tyre and check for level and parallel action.
- Activate press and lower piston until the tyre fits on the rim. The piston should be lowered continuously, without interruption.

Pressing off tyres with steel wire reinforcement (fig. 6)

- Place expansion ring **C** on press table.
- Place rim **D** filled with tyre **B** on the expansion ring **C** and centre carefully.
- Place pressure ring **A** symmetrically on top and lower piston.

Pressing on tyres with steel base (fig. 5)

- Position rim **D** on press table, centring **E** the support ring under it.
- Lightly lubricate steel contact areas of rim and tyre **B** with oil or grease.
- Centre tyre **B** on top of the rim **D** and then centre pressure ring **A** on tyre. Check for level and parallel action

An expansion ring is not to be used.

Pressing off tyres with steel base (fig. 7)

- Place support ring **E** on press table.
- Position rim **D** with tyre **B** on support ring **E** and centre carefully.
- Centre pressure ring on top and lower piston.

With small steel base tyres the actions of pressing on and pressing off can be combined, whereby the old tyre is pushed off when the new tyre is pressed on (fig. 8).

Continental press on bands – Fitting instruction for tapered base type



Fig. 1

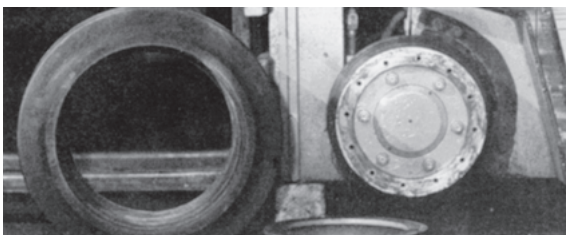

Fig. 2



Fig. 3

Elastic tyres with tapered base can be changed easily and quickly on site without the use of special tools. No hydraulic press is needed and the vehicle only has a very short downtime.

Rims

Precondition for a secure fit of the tyre is the use of rims of the correct size.

Previously used rims should be cleaned before tyre fitting. Damage and burrs caused by running into obstacles should be removed from the rim edges. Tolerances for the rim outer diameter can be found in ISO/R 286, tolerance is 12.

Fitting and removal

Tyres with tapered base can only be used on split rims or double disc wheels. Fitting and removal is carried out by lightening or removing rim nuts, whereby the inner rim section can remain bolted to the hub.

Removing the pressed-on tapered base sections from the rim is made easier by loosening the nuts holding the narrow rim section by three turns only and then driving the vehicle at moderate speed in circles for a while, until the tyre comes off the wide rim section.

After this the vehicle is jacked up, the wheel nuts removed and the narrow section taken off together with the tyre (fig. 1).

The wide tapered inner section of the new tyre is rubbed down with talcum (fig. 2).

The tyre is then placed on to the wide rim section, the narrow section is put in position and the nuts are lightened (fig. 3).

The nuts must be evenly tightened crosswise with the torque recommended by the vehicle manufacturer and must be rechecked after several hours of service.

Notes

Notes

Service

D	Continental Aktiengesellschaft Headquarter Germany: Büttnerstraße 25 30165 Hannover Postfach 169 30001 Hannover		Telefon: ++49 511-93 8-01 Telefax: ++49 511-9 38-27 66 Telegramm: Continental Internet: http://www.conti-industrial-tyres.com
A	Semperit Reifen G.m.b.H. Marketing+Vertrieb Österreich	Wienersdorfer Straße 20-24 2514 Traiskirchen	Tel.: 0043-2252-501-0* Fax: 0043-2252-501-2003
B	Continental Benelux sa/nv	Excelsiorlaan 61 1930 Zaventem	Tel.: 00 32-27 10 22 11 Fax: 00 32-27 10 22 90
CZ	Barum Continental spol. sr. o.	Objízdna 1628 765 31 Otrokovice	Tel.: 00 42-57 75 12-6 08 Fax: 00 42-57 75 12-6 96
CH	Verwaltung Continental Suisse S.A.	Lerzenstrasse 19 Postfach 840 8953 Dietikon 1	Tel.: 0041-1/7455600 Fax: 0041-1/74556 30
DK	Continental Danmark A/S	Dæk Park Allé 370 2605 Brøndby	Tel.: 00 45-43 23 04 00 Fax: 0045-43230401
E	Continental Industrias del Caucho S.A.	Avda. de Castilla, 1 Edificio 1, Planta 2 E-28830 S. Fernando (Madrid)	Tel.: 00 34-91-66 03 60 Fax: 00 34-91-6 56 48 36
F	Continental France FNC Division Commerce Lieu dit «Le Bac à l'Aumône»	B.P.10519 – Clairoix 60205 Compiègne Cedere	Tel.: 00 33-3-44 40 71 11 Fax: 00 33-3-44 40 71 00
GB	Head Office: Continental Tyre Group Ltd.	191-195 High Street, WestDrayton, Middlesex, UB7 7QP	Tel.: 00 44-18 95 42 59 00 Fax: 00 44-18 95 42 59 82
I	Continental Italia S. p. A.	Via Pietro Rondoni 1, 20146 Milano	Tel.: 00 39-2-42 41 01 Fax: 00 39-2-42 41 02 00
NL	Continental Banden Groep B.V.	Nijverheidsweg 50 3771 ME Barneveld	Tel.: 00 31-3-42-49 79 11 Fax: 00 31-3-42-49 73 80
N	Continental Dekk Norge A/S	Smalvollvejen 58 0611 Oslo	Tel.: 00 47-23 06 80 00 Fax: 00 47-23 06 80 01
P	Conti Pneus Pneus da marca Continental S.A.	Lousado 4764-603 Rua Adelino Leitao, 330 Apartado 5029	Tel.: 0 03 51-52-49 98 29 Fax: 0 03 51-52-49 36 23
PL	Continental Opony Polska	AL. Krakowska 2 a PL 02-284 Warschau	Tel.: 00 48-22-5 77 13 00 Fax: 00 48-22-5 77 13 01
S	Continental Däck Sverige AB	P.O. Box 31174 Första Langgatan 30 VI 40032 Gothenburg	Tel.: 00 46-31-7 75 80 00 Fax: 00 46-31-24 68 50
SF	Continental Rengas Oy	PL 133 Hlahdenkatu 27 A 00211 Helsinki	Tel.: 0 03 58-9-32 99 00 Fax: 0 03 58-9-32 99 04 00
USA	Continental General Tire, Inc.	1800 Continental Blvd. Charlotte, NC, 28273-6311	Tel.: 001-704-583-39 00 Fax: 001-704-583-85 40
RSA	Continental Tyre South Africa (PTY) Ltd.	Cadle Street New Brighton West 6001 Port Elizabeth	Tel.: 00 27-41-406-51 11 Fax: 00 27-41-41 23 54

